

5-1-2015

# The Changing Role of the Bass Clarinet: Support for Its Integration into the Modern Clarinet Studio

Jennifer Beth Iles

*University of Nevada, Las Vegas*, [ilesj@unlv.nevada.edu](mailto:ilesj@unlv.nevada.edu)

Follow this and additional works at: <http://digitalscholarship.unlv.edu/thesesdissertations>

 Part of the [Curriculum and Instruction Commons](#), [Music Commons](#), and the [Performance Studies Commons](#)

---

## Repository Citation

Iles, Jennifer Beth, "The Changing Role of the Bass Clarinet: Support for Its Integration into the Modern Clarinet Studio" (2015). *UNLV Theses/Dissertations/Professional Papers/Capstones*. Paper 2367.

This Dissertation is brought to you for free and open access by Digital Scholarship@UNLV. It has been accepted for inclusion in UNLV Theses/Dissertations/Professional Papers/Capstones by an authorized administrator of Digital Scholarship@UNLV. For more information, please contact [digitalscholarship@unlv.edu](mailto:digitalscholarship@unlv.edu).

THE CHANGING ROLE OF THE BASS CLARINET: SUPPORT FOR ITS  
INTEGRATION INTO THE MODERN CLARINET STUDIO

By

Jennifer Beth Iles

Bachelor of Music Education

McNeese State University

2005

Master of Music Performance

University of North Texas

2008

A doctoral document submitted in partial fulfillment of the requirements for the

Doctor of Musical Arts

Department of Music

College of Fine Arts

The Graduate College

University of Nevada Las Vegas

May 2015

We recommend the dissertation prepared under our supervision by

**Jennifer Iles**

entitled

**The Changing Role of the Bass Clarinet: Support for Its Integration into the  
Modern Clarinet Studio**

is approved in partial fulfillment of the requirements for the degree of

**Doctor of Musical Arts**

Department of Music

Marina Sturm, D.M.A., Committee Chair

Cheryl Taranto, Ph.D., Committee Member

Stephen Caplan, D.M.A., Committee Member

Ken Hanlon, D.M.A., Committee Chair

Margot Mink Colbert, B.S., Graduate College Representative

Kathryn Hausbeck Korgan, Ph.D., Interim Dean of the Graduate College

May 2015

## ABSTRACT

The bass clarinet of the twenty-first century has come into its own. Composers often treat it as a solo instrument and clarinetists are more often expected to play bass clarinet. In the last half of the twentieth century, the amount of literature for bass clarinet has grown and the quality of the instruments have improved exponentially. Still, most university studios focus primarily on B-flat clarinet. This document is intended as a pedagogical guide for the inclusion of the bass clarinet in the clarinet studio. As support for incorporating the bass clarinet into the undergraduate curriculum, this document describes three areas of development: historical, pedagogical, and the development of literature. In addition, a survey and interviews were conducted in order to gain perspective on current attitudes about teaching and playing bass clarinet. Participants in the study consist of leading bass clarinet pedagogues in higher education, soloists/specialists, and orchestral players known internationally. Chapter 1 focuses on the history of the bass clarinet, beginning with the evolution of bass clarinet designs, followed by an overview of its changing role in the orchestra, chamber ensemble, band, and as a solo instrument. Chapter 2 focuses on pedagogy beginning with performance issues unique to the bass clarinet, followed by an examination of curricula from various types of university programs including those that offer specialty degrees in bass clarinet, those with degrees in multiple woodwind performance, and those with only a foundation in B-flat clarinet studies. Chapter 3 provides a selected, annotated bibliography of bass clarinet literature and criteria for suggested levels of study. Categories of music include “Warm-ups,” “Scale Studies,” “Methods, Guides and Studies,” “Orchestral Excerpts,” “Concerti,” “Works with Piano,” and “Unaccompanied Solo Bass Clarinet.” Chapter 4 is

a culmination of the previous chapters and begins with results from the bass clarinet questionnaire, followed by the suggested course guide. The guide ranks literature appropriate for students from freshmen through graduate and professional levels. Bass clarinet literature is shown in conjunction with clarinet literature.

## ACKNOWLEDGEMENTS

This project was made possible with the help and support of several people. I would like to first acknowledge those who participated in the study; your thoughts and ideas about teaching bass clarinet helped shape the outcome of the dissertation. Thanks to the members of my committee Marina Sturm, Cheryl Taranto, Stephen Caplan, Kenneth Hanlon, and Margot Mink Colbert for your guidance throughout this process, and to those members of the faculty who have provided support along the way. I would also like to acknowledge my former instructors John Scott, and Jan Scott, who have continued to be mentors over the years. Finally, I could not have done this without the support of close friends in the Livingston Community Band, and my family, especially my mother, Jeanet Iles, and my father, Bill Iles, who have encouraged me in all of my endeavors. Most of all, I'd like to thank my husband Colin Davis; I could not have done this without your unwavering love and support.

## CONTENTS

LIST OF TABLES.....	ix
LIST OF FIGURES .....	x
<b>Chapter 1 The Development of the Bass Clarinet.....</b>	<b>1</b>
Introduction.....	1
Review of Literature.....	3
The Historical Development of the Bass Clarinet.....	5
The Historical and Changing Role of the Bass Clarinet in Orchestra .....	12
<i>Saverio Mercadante (1795-1870)</i> .....	13
<i>Richard Wagner and His Influence on Other Composers, Particularly             Richard Strauss</i> .....	17
<i>Gustav Mahler (1860-1911)</i> .....	21
<i>Richard Strauss (1864-1949)</i> .....	23
<i>Igor Stravinsky (1882-1971)</i> .....	25
<i>Other composers</i> .....	26
Bass Clarinet in Band.....	27
Bass Clarinet Soloists.....	36
<b>Chapter 2 Performance Issues and Model Programs of Study.....</b>	<b>43</b>
Performance Issues for Bass Clarinet.....	43
<i>Selmer and Buffet Low C Bass Clarinets</i> .....	43
<i>Clefs, Notation, and Transposition</i> .....	53

	<i>Extended Techniques and Extended Range</i> .....	56
	<i>Switching from Soprano to Bass Clarinet</i> .....	57
	University Programs that Serve as Models for the Suggested Curriculum .....	63
	<i>Programs with Specialization in Bass Clarinet</i> .....	64
	<i>Programs that Offer Multiple Woodwind Degrees</i> .....	75
	<i>Traditional Programs</i> .....	76
<b>Chapter 3</b>	<b>Bass Clarinet Literature Methods and Studies</b> .....	77
	Criteria for Literature Classification .....	77
	Methods and Studies .....	79
	<i>Warm-ups and Introductory Methods</i> .....	80
	<i>Scale Studies</i> .....	81
	<i>Methods, Guides, and Studies</i> .....	81
	Orchestral Excerpts .....	83
	Concerti .....	84
	Works with Piano .....	87
	Solo Bass Clarinet .....	91
	Clarinet Literature and Studies also for Bass Clarinet .....	95
<b>Chapter 4</b>	<b>Questionnaire Results and Suggested Course of Study for the Incorporation of the Bass Clarinet into the Clarinet Studio</b> .....	97
	Questionnaire Format and Procedure .....	97
	General Questions .....	98
	Equipment .....	101

<i>Instruments</i> .....	101
<i>Mouthpieces</i> .....	104
Literature .....	106
<i>Methods</i> .....	106
<i>Orchestral Excerpts</i> .....	108
<i>Solo Literature with Accompaniment: Original and Transcribed Works</i> ...	110
<i>Bass Clarinet Alone</i> .....	113
<i>Chamber Music</i> .....	115
Interviews .....	119
<i>Interview 1</i> .....	120
<i>Interview 2</i> .....	122
<i>Interview 3</i> .....	123
Conclusion.....	125
Suggested Course of Study for the Integration of the Bass Clarinet into the Clarinet Studio .....	130
BIBLIOGRAPHY .....	147
VITA.....	155

## LIST OF TABLES

Table 1	Timeline of Changes: Buffet and Selmer Bass Clarinets.....	52
Table 2	Orchestral Excerpts with German Notation, Mixed Notation, Transposition.....	55
Table 3	Amsterdam Conservatory Course Description: Bachelor’s Degree in Bass Clarinet .....	65
Table 4	Amsterdam Conservatory: Admissions for Master of Music in Bass Clarinet....	66
Table 5	Amsterdam Conservatory Course Description: Master’s Degree in Bass Clarinet .....	67
Table 6	Conservatory of Milan: Master’s Degree in Bass Clarinet 2013/2014.....	69
Table 7	Conservatory of Milan: Master’s Degree in Bass Clarinet 2014/2015.....	70
Table 8	Boston Conservatory: Audition Requirements for Clarinet with a Specialization in Bass Clarinet.....	71
Table 9	Questionnaire Results: Bass Clarinet Method Books .....	107
Table 10	Questionnaire Results: Bass Clarinet Orchestral Excerpt Books.....	109
Table 11	Questionnaire Results: Bass Clarinet Solos with Accompaniment .....	111
Table 12	Questionnaire Results: Bass Clarinet Alone .....	114
Table 13	Questionnaire Results: Chamber Music with Bass Clarinet .....	117

## LIST OF FIGURES

Figure 1	Saverio Mercadante Act II, <i>Emma d'Antiochia</i> – bass clarinet excerpt .....	14
Figure 2	Giacomo Meyerbeer, <i>Trio, "Interrogatoire," Act 5, Les Huguenots</i> .....	15
Figure 3	Richard Wagner, <i>Tannhäuser</i> , Act 3, scene 1, "Elizabeth's Prayer" .....	18
Figure 4	Richard Wagner, <i>Tristan und Isolde</i> , Act II from <i>Tristan und Isolde</i> .....	19
Figure 5	Wagner, "Isolde's Love Death," from <i>Tristan und Isolde</i> (1857-59) .....	21
Figure 6	Gustave Mahler, Symphony No. 2, Movement 1 – bass clarinet /English horn ..	22
Figure 7	Gustave Mahler, Symphony No. 7, Mvt. 3, <i>Satz</i> (Scherzo) .....	23
Figure 8	Richard Strauss, <i>Don Quixote</i> .....	24
Figure 9	Igor Stravinsky, <i>The Rite of Spring</i> .....	25
Figure 10	Holst: First Suite in E-flat Movement 2 .....	34
Figure 11	Koh: Dithyrambos .....	35
Figure 12	Ticheli: Blue Shades .....	35
Figure 13	Henri Bok, Buffet Bass Clarinet Fingering Guide .....	45
Figure 14	Jason Alder, Buffet BC1193 "Prestige" Fingering guide .....	47
Figure 15	Clark Fobes, Selmer Model 33 – back three thumb keys with adjustment .....	49
Figure 16	Henri Bok, Selmer key positions .....	51
Figure 17	The High and Extremely-high Range .....	56

## **Chapter 1**

### **The Development of the Bass Clarinet**

#### Introduction

Standard undergraduate degree programs for clarinet performance are based on a core of literature designed to prepare students for jobs in orchestras, bands, and as solo recitalists. Although clarinet degrees typically include both traditional and contemporary literature, a gap, or a lack of instruction for teaching multiple clarinets, particularly bass clarinet, still exists between university studies and the realities of the job market. Jobs performing on the clarinet are often limited and many do not offer a livable wage. Therefore, clarinetists develop careers by finding alternative means of employment, generally as music teachers or by creating their own niche in the music community. Creativity, versatility, and entrepreneurship with vision beyond traditional ensembles are skills that students studying performance must acquire, and skills that would benefit pedagogues and students studying music education. How can one better prepare clarinet students for today's demands in the music industry while still maintaining roots in traditional study? By including the study of auxiliary clarinets, particularly the bass clarinet, in the core curriculum, students can become more versatile and marketable musicians.

Currently bass clarinet performance is on the rise as a solo instrument, chamber ensemble instrument, and as a voice for new music. Over the course of the twentieth-century the role of the bass clarinet has evolved into a virtuosic solo instrument for several reasons. Musicians such as Eric Dolphy, Josef Horák, Henri Bok, and Harry Sparnaay built careers as bass clarinet soloists, inspiring new generations of performers

such as Michael Lowenstern and Lori Freedman to pursue similar career paths.

Refinements in design and mechanics have improved tone, intonation, and technical proficiency so that the instrument is much easier to play. Composers, attracted to its wide range of color and dynamics, have begun to write more works for bass clarinet, and the growing body of literature includes solo, chamber, and orchestral music.

It may seem that the bass clarinet is simply a larger version of soprano clarinet that would not require extensive study.<sup>1</sup> However, playing bass clarinet is quite involved and offers a host of unique problems and, therefore, cannot be addressed by simply studying soprano clarinet. Particular obstacles include reading different notations, changes in voicing, switching between soprano and bass, and becoming proficient in the extended range. The notations bass clarinetists are expected to read are, French, treble clef sounding an octave lower than soprano clarinet, German, bass clef, sounding a major second lower than written, and mixed, involving rules for both German and French. Voicing, which refers to the tongue position in various ranges of the instrument, is slightly different on bass clarinet as compared to clarinet and is especially challenging when switching between instruments. Traditional soprano clarinets extend to low E. However, the low C bass clarinets have low E-flat, low D, low D-flat, and low C. These keys involve thumb, extended pinky keys, as well as alternate keys, which change placement depending on the model and age of the bass clarinet.

The purpose of this document is to present a suggested program of study for the clarinet and bass clarinet to be taught simultaneously at the undergraduate level. As

---

<sup>1</sup> Oxford music refers to soprano clarinet as “the principal member of the clarinet family, pitched in B-flat, A, or C.” Clarinets outside of these are considered auxiliary clarinets, such as the E-flat clarinet, basset clarinet, basset horn, bass clarinet and contrabass clarinet.; "Soprano clarinet." *The New Grove Dictionary of Jazz*, 2nd ed.. Grove Music Online, Oxford Music Online, Oxford University Press, accessed February 1, 2015, <http://www.oxfordmusiconline.com/subscriber/article/grove/music/J421500>.

support for its inclusion in the clarinet studio, the first portion of the document describes the evolution of the bass clarinet with focus on four areas of development: (1) mechanical and design improvements, (2) its role in the orchestra, (3) its role in the band, and (4) its role as a solo instrument. The second portion is pedagogically based, focusing on five areas: (1) performance issues and solutions particular to the bass clarinet, (2) an account of programs that currently offer specialization in bass clarinet, those programs that offer specialization in multiple woodwinds, and well-established programs that offer specialization in clarinet, (3) results of the bass clarinet questionnaire, (4) an annotated guide to selected bass clarinet works, and (5) a suggested guide for literature at the undergraduate level that incorporates the bass clarinet into the clarinet studio.

As Henri Bok stated in his article “Bass Clarinet” from *The Versatile Clarinet*, edited by Roger Heaton, “Looking back at the instrument’s history over the last half century, it is evident that the bass has been emancipated and has developed from a rather obscure instrument into one of the major voices of new music.”<sup>2</sup>

### Review of Literature

*The Clarinet* by F. Geoffrey Rendall, published in 1954, is a survey of the history and evolution of the bass clarinet. Rendall gives an account of bass clarinet developments from 1750, the approximate date for early plank-shaped bass clarinets, through 1838, when Adolphe Sax invented his bass clarinet. Significant works up through 1954 are mentioned, as well as a brief explanation of bass clarinet notation.<sup>3</sup>

---

<sup>2</sup> Henri Bok, “The Bass Clarinet,” in *The Versatile Clarinet*, ed. Roger Heaton (New York: Taylor & Francis Group, 2006), 98.

<sup>3</sup> Geoffrey F. Rendall, *The Clarinet* (New York: Philosophical Library Inc., 1954).

Following a similar historical outline as Rendall, Oskar Kroll's book, *The Clarinet*, 1968, offers a more in-depth look at modern, twentieth-century instruments and literature. New improvements at the time of Kroll's publication include extensions to low C and optional automatic speaker keys. An explanation of French and German notation and transposition for bass clarinet in A is included.<sup>4</sup>

*Woodwind Instruments and Their History* by Anthony Baines, revised 1991, begins with the modern bass clarinet design by Adolf Sax from 1838 and includes a detailed description of key work and body dimensions for German and French bass clarinets. Rendall is referenced for an in-depth history of earlier instruments.<sup>5</sup>

*The Clarinet* by Eric Hoeprich published in 2008 includes a very detailed account of bass clarinet history. Unlike Rendall and Kroll, Hoeprich describes the bass clarinet as evolving from the bassoon and straight-shaped models. A description of early eighteenth-century prototypes is followed by a detailed account of nineteenth-century bass clarinets by Gottfried Streitwolf (bassoon-shaped), Isaac Dacosta, L.A. Buffet, and Adolphe Sax (straight-shaped). The final section focuses on twentieth-century bass clarinet literature and describes solo works and significant orchestral and chamber works, followed by information about methods and modern bass clarinet techniques.<sup>6</sup>

The most in-depth history of the bass clarinet is Albert Rice's *From the Clarinet d'Amour to the Contra Bass* published in 2009. This book approaches the history of the bass clarinet from two angles; looking chronologically at the shapes, makers, and development of literature. Rice categorizes early bass clarinets according to shape

---

<sup>4</sup> Oskar Kroll and Diethard Riehm, *The Clarinet. Revised and with a repertory* (New York: Taplinger Pub. Co., 1968).

<sup>5</sup> Anthony Baines, *Woodwind Instruments and their History*, rev. ed. (New York: Dover Publications Inc., 1991).

<sup>6</sup> Eric Hoeprich, *The Clarinet* (New Haven: Yale University Press, 2008).

including seven: plank, curved, bassoon, serpent, straight, ophicleide, and straight with butt joint. The book includes biographies of various makers and performers, and a discussion of experimental bass clarinet designs from 1750 through 1860. Although the design of the bass clarinet was essentially solidified after 1860 more developments have since taken place.<sup>7</sup>

John Henry Van der Meer's article "Typology of the Bass Clarinet," published in the *Journal of the American Musical Instrument Society*, 1987, describes early bass clarinet designs in-depth. The article gives a clear outline of how the instrument developed and includes a description of the early bass chalumeau in Salzburg.<sup>8</sup>

"The Structural Development of the Bass Clarinet," a dissertation by David Lewis Kalina, includes a very detailed account of developments and improvements to the bass clarinet, makers, and models. Kalina's dissertation follows the development up until the time that the document was completed in 1973. However, there have been further improvements since that time.<sup>9</sup>

### The Historical Development of the Bass Clarinet

The earliest documented bass clarinets date from approximately 1750, and the years 1750-1860 are considered to be the experimental period for bass clarinet design.<sup>10</sup>

---

<sup>7</sup> Albert R. Rice, *From the Clarinet d'Amour to the Contra Bass: A History of Large Size Clarinets, 1740-1860* (New York: Oxford University Press, 2009).

<sup>8</sup> "Simple rustic reed-pipe, ancestor of CLARINET, with 6 to 8 finger-holes," "Chalumeau," *The Oxford Dictionary of Music*, 2nd ed. rev., Oxford Music Online, Oxford University Press, accessed March 30, 2015, <http://www.oxfordmusiconline.com/subscriber/article/opr/t237/e1990>; John Henry Van der Meer, "The Typology and History of the Bass Clarinet," *Journal of the American Musical Instrument Society* 13, no. 1 (1987): 65-88.

<sup>9</sup> David Lewis Kalina, "The Structural Development of the Bass Clarinet" (PhD diss., Columbia University, 1972).

<sup>10</sup> Rice, 250.

During this period, bass clarinets were developed in a variety of shapes by many different instrument makers. Although instruments of the twentieth century are based on Adolphe Sax's straight-shape model from 1838, it was not until the twentieth century that a standard shape was solidified. Because early bass clarinets vary drastically in shape, it is sometimes questionable as to whether extant instruments are actually bass clarinets. According to Hoepfich, "for an instrument to qualify as a bass clarinet, it must be pitched an octave below the soprano clarinet, in B-flat, C or in A, and have the basic characteristics of any clarinet: a cylindrical bore and the ability to overblow a twelfth."<sup>11</sup> A brief survey of instruments from 1750 through Adolphe Sax's model in 1838 follows.

The predecessor to the bass clarinet is the bass chalumeau; two have been documented. First is a five-key bass chalumeau by W. Kress in the *Museum Carolino Augusteum* in Salzburg still exists, and the second single-key bass chalumeau, located in Berlin, was destroyed in a fire.<sup>12</sup> The bass chalumeau that still survives has a cylindrical bore and is pitched in C.<sup>13</sup> In the past there was some question as to whether the Kress instrument and the Berlin instrument were bass clarinets or bass chalumeaux. Bass chalumeaux are similar to bass clarinets, but are limited in range to about a twelfth. The addition of the register key allows the instrument to overblow a twelfth and expand the range; therefore, bass clarinets are distinguished from bass chalumeaux because they are capable of overblowing a twelfth.<sup>14</sup> The Kress and Berlin instruments are not capable of overblowing a twelfth, which confirms that they are bass chalumeaux.<sup>15</sup>

---

<sup>11</sup> Hoepfich, 259.

<sup>12</sup> John Henry Van der Meer, 65; Kalina, 14.

<sup>13</sup> Van der Meer, 67.

<sup>14</sup> Roland Jackson, *Performance Practice: A Dictionary-Guide for Musicians* (New York: Routledge, 2005).

<sup>15</sup> Rice, 252.

In 1765, Anton and Michael Mayrhofer developed a sickle-shaped instrument, which most likely developed from their experiments with sickle-shaped basset horns.<sup>16</sup> Because the “label at the Munich Stadtmuseum designates it as a basset horn,” there has been some question as to whether it is actually a bass clarinet. However, measurements of the extant instrument indicate that it is a bass clarinet, and it overblows a twelfth and sounds an octave below the clarinet in B-flat.<sup>17</sup>

An early bassoon-shaped instrument, the *basse de clarinette*, or *bass-tube* is the first documented design invented by Gilles-Lot in 1772.<sup>18</sup> Since then, bass clarinets have undergone several design and shape changes, the two most significant being bassoon and straight-shaped.<sup>19</sup> Heinrich Grenser’s 1793 *clarinettenbass* was also bassoon-shaped and designed for use in military bands to replace bassoons, which was a common use of the bass clarinet at the time.<sup>20</sup> Other bassoon-shaped instruments include Sautermeister of Lyon’s metal *basse-orgue* (1812), G. Catlin’s *clarion* (1813), bass clarinets by G. Streitwolf of Gottingen (1828-1829), George F. Wood of London (1833), Caterrini Caterrino’s *polifono* (1833), Anton Amer’s bass clarinet (1835), and Louis Müller’s bass clarinet (1846).<sup>21</sup>

Serpent-shaped bass clarinets by Nicola Papalini were experimental and six still survive, dating from 1820 to 1829.<sup>22</sup> Designed to address the problem of reaching the

---

<sup>16</sup> Rice, 254.

<sup>17</sup> Ibid., 255-256.

<sup>18</sup> Hoeprich, 259; Kalina, 14.

<sup>19</sup> Hoeprich, 271.

<sup>20</sup> Ibid., 261; Roger Heaton and Henry Bok, “The Bass Clarinet,” *The Versatile Clarinet* (New York: Taylor & Francis Group, 2006), 91.

<sup>21</sup> Rice, 322-323.

<sup>22</sup> Ibid., 283; The serpent is “A wind instrument consisting of a sinuously curved, widely conical wooden tube with six fingerholes, a metal crook extending from it, and a cup mouthpiece similar in size to that of a trombone. Up to 13 keys were added on later models. Initially devised as a bass instrument to support voices in French churches, it became a popular military instrument throughout Europe, and the orchestral

keys, the serpent-shape is a folded, winding tube that places the keys closer together, but results in an awkward fingering-system and oversized tone-holes that are difficult to cover.<sup>23</sup> Papalini's bass clarinets also lack an extended lower range, and this combined with the awkward fingering system may have been why the design never became popular.<sup>24</sup>

The earliest straight-shaped bass clarinet had ten keys and was invented in 1807 by Desfontenelles of Lisieux, a clock maker.<sup>25</sup> L.A. Buffet also developed a ten-key straight-shaped bass clarinet in 1834 and his designs after 1843 would incorporate the Boehm system and moveable rings.<sup>26</sup> The most significant straight-shaped instrument was by Adolf Sax in 1838, and would become the model for the modern, twentieth-century bass clarinet.<sup>27</sup> Sax's bass clarinet was more proportional and featured plateau keys to help cover tone-holes.<sup>28</sup> Other makers of straight-shaped instruments include Eduard Skorra (1840), Darche (1845), Johann Tobias Uhlmann (1845), Buffet-Crampon (1850), and Pierre Paul Ghislain Joseph Dupré (1850).<sup>29</sup>

In 1847, Frédéric Widemann developed a boxwood bass clarinet in low C, which was most likely bassoon or ophicleide-shaped.<sup>30</sup> A letter from Albert Rice describes Wideman and his ophicleide-shaped bass clarinet.<sup>31</sup>

---

brass bass before the invention of the OPHICLEIDE and the TUBA. Its wide bore gives it a rich tone, which ensured its popularity in village bands. The necessity of bringing the fingerholes within the human hand encourages a very flexible fingering and lip technique to achieve accurate tuning." Jeremy Montagu, "Serpent," *Oxford Music Online*, accessed April 13, 2015, <http://www.oxfordmusiconline.com/subscriber/article/opr/t114/e6111>.

<sup>23</sup> F. Geoffrey Rendall, *The Clarinet* (New York: Philosophical Library Inc., 1954), 150.

<sup>24</sup> Rice, 286.

<sup>25</sup> *Ibid.*

<sup>26</sup> *Ibid.*

<sup>27</sup> Kalina, 70-71.

<sup>28</sup> Rice, 292.

<sup>29</sup> *Ibid.*, 322-323.

<sup>30</sup> *Ibid.*, 283.

The Paris instrument maker, Frédéric Widemann, was active in Paris from about 1835 until about 1850. His unusual ophicleide-shaped bass clarinets are quite beautifully designed, as was Buffet-Crampon's version of this instrument. Since it is so compact it makes a good choice for a marching band instrument, which I believe was its purpose.<sup>32</sup>

Several other instrument makers produced ophicleide-shaped bass clarinets. G. Bimboni's *bimbonclaro* (1849), L. A. Buffet (1850), Martin Feres (1850), Buffet-Crampon (1850), Franz Losschmidt and Joseph Uhlmann (1854), Anton Nechwalsky (1853), Franz Carl Kruspe and Franz Walsch (1855), and Johann Wenzel Lausmann (1860) were also known to produced ophicleide-shaped instruments.<sup>33</sup>

One model, critical to the development of the bass clarinet, was the *basse guerrière* designed in 1808, by M. Dumas of Paris.<sup>34</sup> Constructed for use in military bands, it was bassoon-shaped, and may have had between ten and thirteen keys.<sup>35</sup> It was approved by the Paris Conservatory in 1811, and eventually adopted by the Imperial Guard.<sup>36</sup> Unfortunately, it was rejected by musicians accustomed to the six-key bass clarinet as they did not want to learn to play the extra keys. Isaac Dacosta, solo clarinetist with the Imperial Guard, most likely influenced this decision.<sup>37</sup> The two must have made amends since Dumas, upon his death in 1832, left the instrument to Dacosta.<sup>38</sup>

---

<sup>31</sup> "Obsolete keyed brass instr. of conical bore and played with cup mouthpiece. Was a development of the SERPENT and existed in alto, bass, and double-bass sizes, but only the bass was much used. [It] was used in military bands and is also [included] in early scores of Mendelssohn, Berlioz, Verdi, and Wagner. Superseded by the bass tuba." "Ophicleide," *Oxford Music Online*, accessed March 30, 2015, <http://www.oxfordmusiconline.com/subscriber/article/opr/t237/e7497>.

<sup>32</sup> Albert Rice, e-mail message to author, February 2, 2014.

<sup>33</sup> *Ibid.*, 323.

<sup>34</sup> *Ibid.*, 262.

<sup>35</sup> *Ibid.*

<sup>36</sup> Pamela Weston, *More Clarinet Virtuosi of the Past* (London: The Panda Group, 2002), 90.

<sup>37</sup> *Ibid.*, 78-79.

<sup>38</sup> Weston, 78.

Dacosta and L. A. Buffet made further improvements to the design in 1836, and this was the instrument Dacosta played in Meyerbeer's *Les Huguenots*.<sup>39</sup>

According to Kalina, the three prominent bass clarinet makers who most influenced the design of today's instruments are Johann Heinrich Gottlieb Streitwolf, Adolphe Sax, and L.A. Buffet.<sup>40</sup>

Streitwolf's bass clarinet, invented in 1828, was bassoon-shaped, consisted of seventeen keys, and was the most advanced model for its time.<sup>41</sup> Designed for military use, the instrument had a range of four octaves and the keys were much easier to reach due to Streitwolf's modifications of the 13-key Mueller-system that was most common to clarinets at the time.<sup>42</sup>

In 1833, Buffet and Dacosta enhanced the design of Dumas' bass clarinet.<sup>43</sup> The earliest surviving model from 1834 is a straight-shaped thirteen-key instrument.<sup>44</sup> The key system is based on the Müller-system, and "according to Fetis, Dacosta states that two or three hours' practice was sufficient to learn the instrument because the bass clarinet differed in only three or four notes from the ordinary clarinet."<sup>45</sup> Buffet also made a bassoon-shaped bass clarinet, similar to Streitwolf's except Buffet's design incorporated the Boehm fingering system.<sup>46</sup>

---

<sup>39</sup> Rice, 348.

<sup>40</sup> Kalina, 49-70.

<sup>41</sup> Rice, 268.

<sup>42</sup> Kalina, 50-51; Iwan Müller was a clarinetist and basset-horn player. In 1809 he developed a 13-key clarinet often known as the "simple-system," which "enhanced intonation due to better placement of tone holes." He also invented the stuffed pad and metal ligature and claimed to have invented the alto clarinet. Pamela Weston, *Oxford Music Online*, accessed on March 30, 2015, <http://www.oxfordmusiconline.com/subscriber/article/grove/music/19320>.

<sup>43</sup> Rice, 288.

<sup>44</sup> *Ibid.*, 288.

<sup>45</sup> *Ibid.*, 288; Hoepflich, 264.

<sup>46</sup> *Ibid.*, 264; Theobald Boehm's system for flutes allowed for better acoustics and easier reach of the keys. This was later applied to the clarinet. Jeremy Montagu, "Boehm system," *Oxford Music Online*, accessed March 30, 2015, <http://www.oxfordmusiconline.com/subscriber/article/opr/t114/e857>.

Although Streitwolf and Buffet improved the design, Sax's bass clarinet stood out above all others. Larger tone-holes, plateau keys, a wider bore, and double register keys improved technical facility, tone and intonation.<sup>47</sup> Extant models have thirteen keys, although Berlioz claims there were twenty-two in his *Treatise on Instrumentation*.<sup>48</sup> Early Sax models had downward pointing bells and a range to low E.<sup>49</sup> According to Kastner and Berlioz, a metal reflector was placed below the bell to project the sound outward.<sup>50</sup> Sax's Belgian patent, 1838 (no. 1,050), shows an additional bell curved upward, which also extends the instrument to low C. Hector Berlioz admired the improvements Sax made to the instrument and noted the evenness of tone quality in all registers.<sup>51</sup>

While Sax's instruments were superior, they were often not accepted, most likely due to jealousy from other instrument makers.<sup>52</sup> At the 1841 Brussels Exhibition, he won the silver medal, although there was a unanimous decision amongst the judges that his bass clarinet was worthy of gold.<sup>53</sup> According to Rice, Sax was criticized for his bass clarinet, and this, paired with the fact that the judges thought he was too young to earn a gold medal, prompted Sax to leave Belgium for Paris in 1842.<sup>54</sup> However, he continued to encounter resistance from Parisian instrument makers, particularly, at the premiere of Donizetti's opera *Don Sebastian*. The orchestra was comprised of several instrument makers who formed a coalition against Sax and refused to play unless his instruments were removed. The demands were met and the premiere went on with the absence of

---

<sup>47</sup> Ibid., 265; Rice, 304.

<sup>48</sup> Hector Berlioz, *Treatise on Instrumentation: A Translation and Commentary*, trans. Hugh MacDonald (Cambridge: Cambridge University Press, 2002), 135.

<sup>49</sup> Hoepfich, 265.

<sup>50</sup> Rice, 293; Hoepfich, 266.

<sup>51</sup> Hoepfich, 266.

<sup>52</sup> Rice, 300-301.

<sup>53</sup> Kalina, 72.

<sup>54</sup> Rice, 300.

Sax's instruments.<sup>55</sup> Despite the setback, Hector Berlioz, Jean-Georges Kastner, and Fromental Halévy supported him financially when he opened his instrument shop in Paris and his designs were promoted by Gioachino Rossini and Giacomo Meyerbeer.<sup>56</sup>

The Sax model is the foundation for today's instrument makers who have continued to improve the bass clarinet through the twentieth century. Selmer and Buffet are currently the two main manufacturers of bass clarinets and include models with a range to low C.<sup>57</sup> The placement of the extended keys has changed significantly throughout the twentieth century, and can be an issue for today's bass clarinetists playing older models. A guide to twentieth- and twenty-first-century changes and improvements of Buffet and Selmer bass clarinets are found in Chapter 2 of this document.

#### The Historical and Changing Role of the Bass Clarinet in Orchestra

Bass clarinets were originally designed to replace bassoons in the wind band, but by the 1830s became a regular part of the opera orchestra.<sup>58</sup> The unique timbre, especially the lower range, was often associated with sorrowful, somber scenes. The earliest opera known to include bass clarinet is Saverio Mercadante's *Emma d'Antiochia*, premiered in Venice in 1834.<sup>59</sup> More significant is the bass clarinet solo in Meyerbeer's 1836 opera, *Les Huelgots*, which influenced composers such as Wagner and Berlioz.<sup>60</sup> Although Mercadante and Meyerbeer wrote very difficult, exposed parts for the bass clarinet,

---

<sup>55</sup> Ibid., 73.

<sup>56</sup> Ibid., 75.

<sup>57</sup> "Buffet Prestige," *Oxford Music Online*, accessed January 3, 2015, <http://www.buffet-crampon.com/en/instruments/bc1193>; "Selmer Privilege," *Oxford Music Online*, accessed January 3, 2015, <http://www.selmer.fr/fiche.php?code=1108045011>.

<sup>58</sup> Rice, 339.

<sup>59</sup> Rice, 342.

<sup>60</sup> Ibid., 339.

neither incorporated it extensively into the woodwind section, reserving it as a solo voice for solemn scenes.<sup>61</sup>

*Saverio Mercadante (1795-1870)*

Although the bass clarinet is used in Act I and Act III, the lengthiest, most demanding solo in Saverio Mercedante's *Emma d'Antiochia* opens the second act.<sup>62</sup> With a span from low C to altissimo G, the solo was most likely inspired and performed by Catterini Catterino at the premiere in 1834. The instrument of choice was Catterino's *polifono*, which was a bassoon-shaped bass clarinet, with plateau keys, pitched in C that he later renamed the *glicibarifono*.<sup>63</sup> Although the *polifono* was a successful model in Italian opera orchestras, it was not known outside of Italy.<sup>64</sup> The solo at the beginning of the second act is composed in bass, tenor, and treble clef (read an octave higher than soprano notation), and requires a great deal of technical competency from the bass clarinetist. A particular issue on today's bass clarinets is reaching and closing the keys, especially the extended low keys, which require more force than the keys of the clarinet, making it more difficult to gain technical dexterity (see Figure 1).

---

<sup>61</sup> Thomas Carr Aber, "A History of the Bass Clarinet as an Orchestral and Solo Instrument in the Nineteenth and Early Twentieth Centuries and an Annotated, Chronological List of Solo Repertoire for the Bass Clarinet from Before 1945," D.M.A. Dissertation (University of Missouri-Kansas City, 1990), 6.

<sup>62</sup> *Ibid.*, 342.

<sup>63</sup> Aber, 343.

<sup>64</sup> Rice, 277.

Figure 1. Saverio Mercadante Act II, *Emma d'Antiochia* – bass clarinet excerpt  
1834, Naples, Italy, *Conservatorio di Musica San Pietro a Majella, Biblioteca, MS., 29.6.9 – 10*, (Figure 5.1., Albert Rice, *From the Clarinet d'Amour to the Contra Bass*) Reprinted with permission from Oxford University Press.

**Emma d'Antiochia**  
Act two  
Scena, Duetto, Terzetto, e Finale  
Saverio Mercadante  
(1834)

Andante

capriccio

a piacere

a piacere

*Giacomo Meyerbeer (1791-1864)*

The bass clarinet solo in *Les Huguenots* by Giacomo Meyerbeer shown in Figure 2 was most likely inspired by Franco Docasta, who performed the premiere on M. Dumas' bass clarinet, modified by L.A. Buffet.

Figure 2. Giacomo Meyerbeer, *Trio, "Interrogatoire," Act 5, Les Huguenots* (Paris, 1836; New York: Garland, 1980), 847. (Figure 5.2. Albert Rice, *From the Clarinet d'Amour to the Contra Bass: A History of Large Size Clarinets from 1740-1860*) Reprinted with permission from Oxford University Press.

**TRIO.**  
(A) INTERROGATOIRE

(Bien que la clarinette basse s'écrive comme la clarinette ordinaire elle rénd les sous une octave plus bas)

Molto maestoso. Métr:  $\text{♩} = 65.$

Clar. basse en si b. *f* *crescendo* *f* *pp* *rallent.* *f* *pp* *(d'un voix grave et triste)* *pp* *(d'un voix haute)*

VALENTINE. *pp* *rallent.* *f* *pp* *(d'un voix grave et triste)* *pp* *(d'un voix haute)*

RAOUL. *pp* *rallent.* *f* *pp* *(d'un voix grave et triste)* *pp* *(d'un voix haute)*

MARCEL. *pp* *rallent.* *f* *pp* *(d'un voix grave et triste)* *pp* *(d'un voix haute)*

Clar. basse. *f* *crescendo* *f* *pp* *rallent.* *f* *pp* *(d'un voix grave et triste)* *pp* *(d'un voix haute)*

Clar. basse. *f* *crescendo* *f* *pp* *rallent.* *f* *pp* *(d'un voix grave et triste)* *pp* *(d'un voix haute)*

Clar. basse. *f* *crescendo* *f* *pp* *rallent.* *f* *pp* *(d'un voix grave et triste)* *pp* *(d'un voix haute)*

mais qu'en joi - gant vos mains dans ces té - uè - - - bres je commue et bé -

ois le banquet des à - dieux et ses no - ces fu - né - - - bres

M. F. 2154

The solo is found in Act V during the somber wedding scene between Raul and Valentine prior to their inevitable death.<sup>65</sup> The scene begins with a bass clarinet cadenza that spans

<sup>65</sup> Ibid., 347; In his dissertation "A History of the Bass Clarinet as an Orchestral and Solo Instrument in the Nineteenth and Early Twentieth Centuries and an Annotated, Chronological List of Solo Repertoire for the

the range from low C to altissimo G in an obbligato role. *Les Huguenots* was a very popular opera at the time, influencing many composers and as a result, the bass clarinet is often associated with solemnity and used as an obbligato<sup>66</sup> instrument with voice.<sup>67</sup>

### *Hector Berlioz (1803-1869)*

Berlioz draws particular attention to the low range of the bass clarinet and uses it to add depth to the clarinet section, and he notes the solemn quality of its tone.

The bass clarinet's role is clearly not to take the place of the higher-pitched clarinets in its upper register but simply to extend their range downwards. There are some very fine effects to be obtained however by doubling the upper notes of the B-flat clarinet an octave lower on a bass clarinet. It is written on the treble clef like the other clarinets, with a range from E to G3 giving actual pitches from D up to F2. Its best notes are its lowest notes, but in view of their slow rate of vibration they must not follow on too quickly one after the other.<sup>68</sup>

Depending on how it is written [for] and how well it is played, this instrument in its low register can take on the uncouth tone of the ordinary clarinet's bottom notes or the calm, solemn, priestly strain of certain organ registration. So it may often be aptly used. Furthermore, if four or five are used in unison in wind bands the bass line acquires an admirably unctuous quality.<sup>69</sup>

Works by Berlioz which include the bass clarinet are *Benvenuto Cellini* (1838), *Grande Symphonie Funèbre et Triomphale* for military band, or optional strings (1842), *Chante Sacré* (1829), *La Damnation de Faust* (1846), and *Te Deum* (1849).<sup>70</sup> Berlioz's use of the bass clarinet was quite different from Meyerbeer's in that Berlioz did not use

---

Bass Clarinet From Before 1945," Thomas Aber discusses the changing role of the bass clarinet in orchestra and points out its association with death in opera. He also discusses the idea of its decline in the early part of the twentieth century.

<sup>66</sup> "In music for voice with instruments, 'obbligato' refers to a prominent instrumental part in an aria or other number," David Fuller, "Obbligato," *Oxford Music Online*, accessed March 30, 2015, <http://www.oxfordmusiconline.com/subscriber/article/grove/music/20202>.

<sup>67</sup> Rice, 349.

<sup>68</sup> Hugh Mac Donald, *Berlioz's Orchestration Treatise: A Translation and Commentary* (Cambridge University Press, 2002): 132, accessed January 19, 2015, <http://quod.lib.umich.edu.ezproxy.library.unlv.edu/cgi/t/text/text-idx?c=acls;idno=heb07653>.

<sup>69</sup> *Ibid.*

<sup>70</sup> Rice, 359-363; Hoepflich, 371.

the bass clarinet purely as an obbligato or solo instrument, but also incorporated it into the wind section to fill out the bass line. Generally, Berlioz utilized the mid to lower range, and without exploring the altissimo register.

*Richard Wagner and His Influence on Other Composers, Particularly Richard Strauss*

An earlier translation of Berlioz's *Treatise on Orchestration* by Strauss, not published until 1948, makes revisions and additions to Berlioz's original treatise.<sup>71</sup> Strauss kept all of the original text and added information about new improvements to instruments and their use in orchestras at the time. He also added musical examples, including those of Wagner. In the article "The Berlioz-Strauss Treatise on Instrumentation" from *Music and Letters*, Edward Lockspeiser points out the differences between Strauss's and Berlioz's styles of writing, particularly that Strauss was heavily influenced by Wagner while Berlioz was influenced by Carl Maria von Weber and Christoph Willibald von Gluck, which may have affected how each viewed the role of the bass clarinet in the orchestra.<sup>72</sup> Strauss's additional statements about the bass clarinet are as follows:

Wagner always used the bass clarinet in the character of solemn resignation; see Elisabeth's prayer in "Tannhäuser" and King Marke's great scene at the end of the second act of "Tristan."<sup>73</sup> (see Figure 3, *Tannhäuser* and Figure 4, *Tristan und Isolde*)

Influenced by Meyerbeer, Wagner first included bass clarinet in his opera *Tannhäuser*, 1845. Although only used in the first scene of the third act, the bass clarinet

---

<sup>71</sup> Hector Berlioz, *Treatise on Instrumentation*, rev. Richard Strauss, trans. Theodore Front (New York: Edwin F. Kalmus, 1948), 222.

<sup>72</sup> Edward Lockspeiser, "The Berlioz-Strauss Treatise on Instrumentation," *Music & Letters* 50, no. 1 (January 1969): 37-44.

<sup>73</sup> Berlioz, rev. Richard Strauss, 222.

plays a critical role during Elisabeth’s prayer for death.<sup>74</sup> A solemn atmosphere is created from the obbligato line in the soft, low register. Wagner embraced the bass clarinet’s ability to play softly and move smoothly in and out of phrases.<sup>75</sup>

Figure 3. Richard Wagner, *Tannhäuser*, Act 3, scene 1, “Elizabth’s Prayer”  
 Edited by Felix Mottl (1856-1211), Leipzig: C.F. Peters, n.d. [1920]. Plate 10352., New York: Edwin F. Kalmus, n.d. (after 1933), Public Domain.

*Lohengrin* is the first opera in which Wagner uses the bass clarinet as a standard part of the wind section.<sup>76</sup> Associated with evil, it is featured more often, but usually in combination with other woodwinds such as the English horn, another unique color instrument.<sup>77</sup> More importantly is *Tristan und Isolde*, composed 1857-1859, a work in which the bass clarinet is used as both an inner voice and solo obbligato instrument.

<sup>74</sup> Hoeplich, 272.

<sup>75</sup> Berlioz, rev. Richard Strauss, 225.

<sup>76</sup> Ibid., 272.

<sup>77</sup> Hoeplich, 272; Barry Millington, *Wagner* (New Jersey: Princeton University Press, 1984), 190.

Figure 4 is King Marke's lament from *Tristan und Isolde*, another moment when the bass clarinet is featured in its traditional role as an obbligato instrument associated with despair.

Figure 4. Richard Wagner, *Tristan und Isolde*, Act II from *Tristan und Isolde* (1857-59). Public Domain.

**No. 91. Tristan, Act II**

**Mäßig langsam.**  
(immer sehr ausdrucksvoll) Wagner.

The score is divided into three systems. The first system includes parts for Bass Clarinet in A, Violins (staccato), Viola, Bass, and King Marke. The second system includes parts for Bass Clarinet in A, Violins, Viola (staccato), Bass, and King Marke. The third system includes parts for Bass Clarinet in A, Violins, Viola, Bass, and King Marke. The vocal line for King Marke includes the following lyrics: "(be-)wahrt. (nach tiefer Erschütterung. mit bebender Stimme.) Tatet das wirklich? Wähnet du das? (nur die 2. Hälfte) sehr getragen. Steh' ihn dort, den treuesten aller Treuen; blick auf ihn, den freundlichsten der Freunde: seiner Treue freiste Tat traf mein Herz mit feindlichen Ver-rath. Trog mich Tristan,

Strauss, in his revision of Berlioz's *Treatise on Orchestration*, notes how Wagner also incorporates the bass clarinet into the wind section in "Isolde's Love Death" (see Figure 5).

As the low tones of the bassoon are still devoid of any flexibility, the bass clarinet is the finest and softest bass for the wood-wind instruments, especially as the lowest voice in combination with three bassoons—cf. Isolde's Love Death.<sup>78</sup>

The role of the bass clarinet as an integral part of the woodwind family and as a solo instrument was truly established in Wagner's compositions and would be adopted by other composers outside of the opera orchestra. The stigma of solemnity, although not always implied, would remain a part of the bass clarinet's character, noted by Nicholas Rimsky-Korsakov in *Principles of Orchestration*, 1873:

The bass clarinet, though strongly resembling the ordinary clarinet, is of darker colour in the low register and lacks the silvery quality in the upper notes; it is incapable of joyful expression.<sup>79</sup>

He notes that the English horn, bass flute, and bass clarinet each "have their own distinctive peculiarities of timbre and are often used in the orchestra as solo instruments, clearly exposed."<sup>80</sup> Gustav Mahler, Richard Strauss and Igor Stravinsky, also utilize the bass clarinet as an integral part of the woodwind section, but display the unique timbre and wide dynamic range through soloistic lines.

---

<sup>78</sup> Berlioz, Strauss Rev., 225.

<sup>79</sup> Nikolay Rimsky-Korsakov, trans. Edward Agate, *Principles of Orchestration, with Musical Examples Drawn from His Own Works*, ed. Maximilian Steinberg (Berlin: Edition russe de musique, 1922), 20.

<sup>80</sup> *Ibid.*, 21.

Figure 5. Wagner, “Isolde’s Love Death,” from *Tristan und Isolde* (1857-59)

(Sehr mässig.) Wagner.

Fl. I. *pp* *cresc.* *f* *dim.* *pp*

2 Ob. *pp* *cresc.* *f* *dim.* *pp*

2 Klar. in A. *pp* *cresc.* *f* *dim.* *pp*

I. II. in E. *pp* *cresc.* *f* *dim.* *pp*

4 Hornr. *pp* *cresc.* *f* *dim.* *pp*

III. IV. in E. *pp* *cresc.* *f* *dim.* *pp*

3 Fag. *pp* *cresc.* *f* *dim.* *pp*

Bassklar. in A. *pp* *cresc.* *f* *dim.* *pp*

Pke. *pp* *cresc.* *f* *dim.* *pp*

Harfe. *pp* *cresc.* *f* *dim.* *pp*

Viol. I. (geteilt) *pp* *molto cresc.* *f* *dim.* *pp*

Viol. II. (geteilt) *pp* *molto cresc.* *f* *dim.* *pp*

Viola. *pp* *molto cresc.* *f* *dim.* *pp*

Isolde. Stern - - - um - strah - - - lei hoch sich hebt? Sieht

Vlc. *pp* *molto cresc.* *f* *dim.* *pp*

K. B. *pp* *cresc.* *f* *dim.* *pp*

### Gustav Mahler (1860-1911)

Mahler wrote for bass clarinet in all of his symphonies. It is doubled in the third clarinet part in Symphony No. 1 through Symphony No. 5, but beginning with Symphony No. 6, Mahler writes independent bass clarinet parts which are not doubled by the third clarinetist. Usually paired with other woodwinds, such as bassoon, and particularly the English horn, the thin textures of Mahler’s symphonies highlight the dynamic range, (especially *piano* and *pianissimo*) and dark timbre of the bass clarinet, adding an extra layer of color to the winds.<sup>81</sup> Symphony No. 2, composed in 1894, is an example of how Mahler features the bass clarinet and English horn at *piano* in unison against the strings,

<sup>81</sup> Colin Lawson and Michael Harris, *The Cambridge Companion to the Clarinet* (Cambridge: Cambridge University Press, 1995), 70-72.

blending the timbre of the two instruments to create a new color within the orchestra (See Figure 6).

Mahler pairs the bass clarinet with other woodwind instruments as well. In the third movement of Symphony No. 7 the bass clarinet plays first with the English horn followed by the addition of bassoons and strings, and then with bassoons again (see Figure 7).

Figure 6. Gustave Mahler, Symphony No. 2, Movement 1 – bass clarinet /English horn  
Gustav Mahler „2. Symphonie“ in 5 Sätzen für Soli, gemischten Chor und Orchester © 1897, 1925, 1952 by Universal Edition AG. Vienna, assigned 1952 to Universal Edition (London) Ltd. London. This revised edition © copyright 1971 by Universal Edition Vienna-London www.universaledition.com

The image displays a page of a musical score for Gustav Mahler's Symphony No. 2, Movement 1. The score is arranged in two systems. The first system includes staves for 1. 2. Fl., engl. Horn, Basscl. in B., 1. Viol., 2. Viol., Viola, Cello, and Bass. The second system includes staves for engl. Horn, Basscl. in B., Viola, Cello, and Bass. The key signature is two sharps (D major or F# minor), and the time signature is 4/4. The score features various musical notations, including dynamics such as *andruksvoll* and *p*, and performance instructions like *spielen* and *die andere Hälfte*. Measure numbers 149 and 154 are indicated at the beginning of their respective staves.

Figure 7. Gustave Mahler, Symphony No. 7, Mvt. 3, Satz (Scherzo)  
 Leipzig: Eulenburg, No. 92. Plate E. E. 3369. Public Domain

*Richard Strauss (1864-1949)*

Richard Strauss' *Till Eulenspiegels lustige Streiche*, Op. 28, and *Don Quixote*, Op. 35, associate the bass clarinet with light-hearted melodies rather than those of despair.<sup>82</sup> Particularly in *Don Quixote*, the bass clarinet represents Quixote's comical sidekick Sancho Panza.<sup>83</sup> The solo is technically demanding with wide leaps and spans the range of the instrument to altissimo D; however, the role of Sancho is not portrayed

<sup>82</sup> Thomas Aber, "A History of the Bass Clarinet as an Orchestral and Solo Instrument in the Nineteenth and Early Twentieth Centuries and an Annotated, Chronological List of Solo Repertoire for the Bass Clarinet from Before 1945" (D.M.A. Dissertation, University of Missouri-Kansas City, 1990), 40

<sup>83</sup> David Bourque, Annotated excerpt from *The Bass Clarinetists' Workbook* (David Bourque, 2013): accessed January 23, 2015, [http://davidbourque.com/clbcl/Downloads\\_files/Strauss%20Don%20Q%20thm%20%26%20sib%20%20only.pdf](http://davidbourque.com/clbcl/Downloads_files/Strauss%20Don%20Q%20thm%20%26%20sib%20%20only.pdf).

by the bass clarinet alone. The solo viola and tenor tuba are also featured, and the tenor tuba is typically in unison with the bass clarinet (see Figure 8).

Figure 8. Richard Strauss, *Don Quixote*  
 Mineola: Dover Publications, 1979. Reprinted with permission from Dover Publications.

14 (Sancho Panza)  
 Maggiore. Metr. ♩ = 96.

II. Clar. (B)  
 Basscl. (B)  
 8 Fag.  
 Tenortuba (B)  
 Bratsche (Solo)

15

kl. Fl.  
 Basscl. (B)  
 8 Fag.  
 Tenortuba (B)  
 Bratsche (Solo)

2 Clar. (B)  
 Basscl. (B)  
 5. u. 8. Horn. (F)  
 Viol. II.  
 Solobratsche  
 Bratschen (die übrigen)

16

Variation I.  
 Gemächlich.  
 (Metr. ♩ = 84.)

kl. Fl.  
 Basscl. (B)  
 3 Fag.  
 4 Horn. (F)  
 5. u. 8. Horn. (F)  
 Tenortuba (B)  
 Basstuba  
 Solobratsche  
 Violone (Solo)

Igor Stravinsky (1882-1971)

Strauss is not the only composer to feature the bass clarinet in technically demanding roles. In Stravinsky's *Rite of Spring* the bass clarinet is an extension of the woodwinds, not only to fill out the bass line, but also as a solo instrument.

Figure 9. Igor Stravinsky, *The Rite of Spring*  
Mineola: Dover Publications, 1989. Reprinted with permission from Dover Publications.

The image displays two systems of musical notation for Igor Stravinsky's *The Rite of Spring*. The first system, labeled with a circled '6', shows measures 6 through 8. The second system, labeled with a circled '7', shows measures 9 through 12. The instruments listed on the left of each system are: Fl. (Flute), Fl. c-a (G) (Flute in C), Ob. (Oboe), C. in G. (Clarinet in G), Cl. (A) (Clarinet in A), Cl. b. (Bass Clarinet), Fag. (Bassoon), Cor. (Cor), Picc. (Piccolo), Cl. picc. (D) (Clarinet in D), Cl. (A) (Clarinet in A), Cl. b. (Bass Clarinet), Fag. (Bassoon), Cor. (Cor), and V.-c. solo (Violoncello solo). The score includes various performance markings such as 'solo', 'solo (en dehors)', 'très en dehors', 'lento', 'mf', 'mp', 'f', 'ff', 'rit.', 'cresc.', 'dim.', 'pizz.', and 'arco'. The bass clarinet part in measure 6 is marked 'solo' and 'mf'. The bassoon part in measure 7 is marked 'solo' and 'mp (très en dehors)'. The violoncello solo part in measure 7 is marked 'pizz.' and 'arco'.

The *Rite of Spring* utilizes two bass clarinets, one doubled in the third clarinet part, and the other as an independent part. The foundation of the ballet is built on

repetitive, rhythmic musical cells in which the bass clarinets play alternative flourishes that stand out of the texture. The technical demands are great, requiring the bass clarinet to leap from the chalumeau to the altissimo range very quickly (see Figure 9).

### *Other composers*

While Mercadante, Meyerbeer, and Wagner embraced the bass clarinet, and Mahler, Strauss, and Stravinsky expanded the repertoire, other composers also recognized the distinct character and depth of color that the bass clarinet could offer. Peter Ilich Tchaikovsky features it in “Dance of the Sugar Plum Fairy,” from the *Nutcracker* (1892) as does Franz Liszt in his *Tasso Lamento e Trionfo* (1854), where the bass clarinet plays the Venetian gondolier’s song.<sup>84</sup> Verdi used the bass clarinet for the first time in *Ernani* (1843) and composed a significant part in *Aida* (1871).<sup>85</sup> Other works that have important bass clarinet parts include Paul Dukas, *Sourcerer’s Apprentice* (1897), Ferde Grofe, *Grand Canyon Suite* (1929-1931), Alban Berg, *Violinkonzert* (1936), Paul Hindemith, *Symphonic Metamorphoses* (1943), and Maurice Ravel, *Daphnis and Chloe* (1909-1911). George Gershwin wrote significant parts for the bass clarinet in works such as *Rhapsody in Blue* (1925), and *An American in Paris* (1928) as did Leonard Bernstein in *Symphonic Dances from West Side Story* (1960).<sup>86</sup>

---

<sup>84</sup> Rice, 370; Michael Drapkin, *Symphonic Repertoire for the Bass Clarinet*, Volume 1 (Glenmore: Roncorp Publications), 24 & 67.

<sup>85</sup> Hoepflich, 272; Drapkin, 18.

<sup>86</sup> Drapkin, 13-14.

## Bass Clarinet in Band

Job opportunities in band can be found in both military and civilian professional wind ensembles. United States military bands offer salaried positions that include health care, housing stipends, paid vacation, and programs for student loan repayment, or tuition for continuing education. Depending on the branch of service, Army, Navy, Marine, or Coast Guard, and the type of band, Premiere bands (those stationed in Washington D.C. and do not deploy), and Regional bands (those stationed throughout the United States that deploy), benefits and pay may vary. There is also employment available in professional, civilian groups such as the Dallas Wind Symphony, the Fort Collins Wind Symphony, and the Miami Wind Symphony and audition requirements vary depending on the group.

Since the first bass clarinets were invented for use in French military bands to double the bassoon line and add depth and color to the bass line, it seems that the bass clarinet would have made the transition to American wind bands from the beginning. However, the first professional band in the United States did not include clarinets or bass clarinets. In 1798 President John Adams established the United States Marine Band, which consisted of 32 drums and fifes.<sup>87</sup> Other American bands varied greatly in instrumentation, and there was no set instrumentation. The 1806 Brigade Band from Salem, Massachusetts included five clarinets and two bassoons, but there is no indication that bass clarinets were used, and other bands of this period included both woodwinds and brass.<sup>88</sup> From the 1830s through the Civil War, brass bands became the major ensemble, leaving woodwinds out entirely.<sup>89</sup> Patrick Sarsfield Gilmore, known as the father of the concert band, changed the instrumentation of the band to include woodwinds

---

<sup>87</sup> Frank L. Battisti, *The Winds of Change* (Galesville: Meredith Music Publications, 2002), 6-7.

<sup>88</sup> *Ibid.*, 6.

<sup>89</sup> *Ibid.*

when he was appointed leader of the Twenty-Second Regiment Band of New York, renaming it the “Gilmore Band.”<sup>90</sup> Most importantly he shifted “the emphasis from brasses to the woodwinds, especially the clarinets,” and “expanded the bands repertoire by adding transcriptions of orchestral music.”<sup>91</sup> In fact, during the nineteenth century bandmen also held positions in orchestras, and the repertoire for both groups consisted of the same works including, overtures, opera arias and marches.<sup>92</sup> The instrumentation for the clarinet section in Gilmore’s 66 piece band in 1878 is as follows:<sup>93</sup>

Gilmore’s Band 1878

- 1 A-flat soprano clarinet
- 3 E-flat soprano clarinets
- 16 B-flat clarinets (8, 1<sup>st</sup>; 4, 2<sup>nd</sup>; 4, 3<sup>rd</sup>)
- 1 Alto clarinet
- 1 Bass clarinet

By 1892 Gilmore expanded the clarinet section and adding an alto and bass clarinet:<sup>94</sup>

Gilmore’s Band 1892

- 1 A-flat soprano clarinet
- 3 E-flat clarinets
- 29 B-flat clarinet
- 2 Alto clarinets
- 2 Bass clarinets

Gilmore died in 1892 while on tour, and although he was known for establishing the first professional band, John Phillip Sousa, the “March King,” became one of America’s greatest bandmaster’s. In 1880 Sousa conducted the United States Marine Band, but resigned in 1892 to begin the Sousa professional band.<sup>95</sup> Sousa’s goal as band leader was to create programs that were entertaining to audiences, and offered a variety

---

<sup>90</sup> Battisti, 8.

<sup>91</sup> Ibid.

<sup>92</sup> Ibid.

<sup>93</sup> Ibid., 9.

<sup>94</sup> Jesse Daniel Krebs, “The Clarinetists of John Philip Sousa Band: 1892-1931” (DMA diss., Florida State University, 2006), 39.

<sup>95</sup> Battisti, 9.

of repertoire including, orchestral transcriptions, solo performances of singers and instrumentalists with band accompaniment, national music, popular music, and his own compositions.<sup>96</sup> Sousa's band was the most popular during the "Golden Age" of American professional bands from 1880 until 1925.<sup>97</sup> Sousa's band of 1892 had fewer clarinets than Gilmore's band, eliminating the A-flat sopranino clarinet, and reducing both the E-flat and B-flat clarinet sections:

Sousa's Band 1892<sup>98</sup>  
0 A-flat sopranino clarinet  
2 E-flat clarinets  
12 B-flat clarinets  
1 alto clarinet  
1 bass clarinet

In 1952 Frederick Fennel would change the evolution of the wind band. As conductor of the Eastman Wind Ensemble he envisioned a wind band with one player to a part, with a primary focus on original literature for band rather than transcriptions.<sup>99</sup>

Clarinet Section: The Eastman Wind Ensemble (1952)<sup>100</sup>  
Frederick Fennel, conductor  
1 E-flat clarinet  
8 B-flat clarinets  
1 alto clarinet  
1 bass clarinet  
1 contrabass clarinet

Future American wind ensembles used a similar instrumentation to Sousa's and Fennel's bands, and typically included several B-flat clarinets and auxiliary clarinets. With regards to the low clarinets, most had one bass clarinet:

---

<sup>96</sup> Battisti, 9.

<sup>97</sup> Ibid.

<sup>98</sup> Krebs, 39.

<sup>99</sup> Richard K. Hansen, *The American Wind Band: A Cultural History* (Chicago: GIA Publications Inc., 2005), 97-98.

<sup>100</sup> Battisti, 347.

Clarinet Section: United States Marine Band (1950)<sup>101</sup>

William F. Santelmann, conductor

- 1 E-flat clarinet
- 12 B-flat clarinets
- 1 alto clarinet
- 1 bass clarinet

Clarinet Section: The Goldman Band (1960)<sup>102</sup>

Richard Franko Goldman, conductor

- 1 E-flat clarinet
- 16 B-flat clarinets
- 1 bass clarinet

Clarinet Section: United States Air Force Band (1988)<sup>103</sup>

- 1 E-flat clarinet
- 12 B-flat clarinets
- 1 bass clarinet
- 1 contra-alto clarinet

Although most university and professional wind bands conform to this instrumentation, the use of the bass clarinet varies to typically include anywhere from zero to four bass clarinets, depending on the preference of the conductor. In 1991, the University of Illinois Symphonic Band included three bass clarinets and, in 1991, the United States Marine band incorporated two bass clarinets. Instrumentation may also vary depending on the piece.

With regards to repertoire, aside from marches there is a great deal of literature for wind band composed during the twentieth century. Early twentieth-century band music for bass clarinet may not have been as challenging as later works. A 1919 article from *Jacob's Band Monthly* by Rudolf Toll, former clarinetists with the Pittsburgh

---

<sup>101</sup> Battisti, 347.

<sup>102</sup> Ibid., 348-349

<sup>103</sup> Ibid., 352.

Symphony, the Boston Opera Orchestra, and Instructor of Clarinet at the New England Conservatory, addresses the question of the role of bass clarinet in band.<sup>104</sup> He writes:

The bass clarinet, though frequently heard in some of our larger bands, as yet has no individual existence. It merely doubles one of the bassoon parts, although it is lacking to the extent of a major third in the extreme low notes which are so often assigned to the second bassoon.<sup>105</sup>

Perhaps the lack of challenging literature during the early part of the twentieth century is why bass clarinet auditions for professional wind bands are not prevalent. The audition process for bass clarinet varies depending on the military band. Chief Musician Cindy Wolverton discusses playing bass clarinet and the audition process for premiere military bands in her article “Bass Clarinetists in Unifrom,” from the September 2014 issue of *The Clarinet*:

Each of the premiere military bands has at least one designated bass clarinetist and usually one or two other players who are responsible for covering the other instruments when there are parts written for them. The selection process for these positions varies. Some of the bands will advertise a bass clarinet opening and hire someone specifically for that chair, while other bands tend to fill the spot with an “in-house” audition, open only to those currently in the clarinet section.<sup>106</sup>

While researching this topic, the only audition lists discovered for military band were for B-flat soprano clarinet. Therefore, bass clarinetists auditioning for military bands should practice excerpts for soprano clarinet as well. The following is the President’s Own Marine Band clarinet excerpt list for the audition held in 2014, which involves a mix of orchestral, chamber, and band excerpts that are most commonly asked in military band auditions:<sup>107</sup>

---

<sup>104</sup> Rudolph Toll, “Questions and Answers,” *Jacob’s Band Monthly* 4 (October, 1919): 89-90.

<sup>105</sup> *Ibid.*, 90.

<sup>106</sup> Cindy Wolverton, “Bass Clarinetists in Unifrom,” *The Clarinet* 41, no. 4 (September 2014): 32.

<sup>107</sup> The President’s Own, “Announces a Vacancy for B-flat Clarinet,” accessed April 22, 2015, [http://www.marineband.marines.mil/portals/175/docs/vacancies/2014\\_clarinet.pdf](http://www.marineband.marines.mil/portals/175/docs/vacancies/2014_clarinet.pdf).

- A) Clarinet Concerto in A, K. 622 (Mozart) – 1st movement only
- B) Excerpts from the following:
  - Ballet Music from Faust (Gounod/Tobani)
  - Symphony No. 3 in F, Opus 90 – 2nd movement (Brahms)
  - Sinfonietta (Dahl)
  - Aegean Festival Overture (Makris/Bader)
  - Serenade No. 10 in B-flat, K. 361 – 6th and 7th movements (Mozart)
  - Overture to Le roi d’Ys (Lalo/Patterson)
  - A Midsummer Night’s Dream – Scherzo (Mendelssohn)
  - Intermezzo from Carmen Suite No. 1 (Bizet)
  - Hammersmith, Opus 52 (Holst)
  - Symphony Nr. 1, The Lord of the Rings – 3rd movement (de Meij)
  - Midway March (Williams/Lavender)
  - Symphony No. 4 in B-flat, Opus 60 – 2nd movement (Beethoven)
  - Pictures at an Exhibition – The Marketplace  
(Mussorgsky/Ravel/Lavender)
- C) Duets (to be performed with a member of the Marine Band clarinet section)
  - The Hebrides Overture, Opus 26 (Mendelssohn)
  - Duet No. 1 (W. F. Bach)
- D) Sight-reading

Although the “President’s Own Marine Band” currently employs two bass clarinetists, an audition list specifically for bass clarinet has not been found. However, the Army Regional Band holds auditions by appointment and clarinetists have the opportunity to select their own audition materials, which consist of pieces performed in three different styles on soprano clarinet. Therefore, clarinetists in professional Army bands may audition on clarinet, but be expected to play bass or E-flat clarinet as well. The job description for clarinet in the United States Army Regional Band is as follows:

As clarinet player in the U.S. Army Bands, you will perform in concert band, ceremonial band, woodwind quintet, and other small groups such as Dixieland band based on your skills and the needs of the band. Clarinet players may also be asked to perform on bass clarinet and/or E-flat clarinet if a piece of music calls for it. Clarinet players who are able to play in various styles or double on other instruments are especially valuable to our program.<sup>108</sup>

---

<sup>108</sup> United States Army, “Auditions,” accessed April 20, 2015, <http://www.music.army.mil/careers/auditions/clarinet/>.

While it is not necessary that clarinetists play bass clarinet in their audition for the United States Army, it is encouraged, and clarinetists are allowed the opportunity to show any additional music skills they may have.

The Army Bands values additional skills that musicians bring to our organization. You may receive additional points on your audition if you choose to demonstrate any of the following: doubling, singing, or improvisation. Please discuss with your band liaison what would be appropriate to prepare should you wish to demonstrate an additional skill.<sup>109</sup>

Aside from military bands, there is great value in performing with university wind ensembles. Every school has a different way of choosing bass clarinetists for the group. My experience playing bass clarinet with The University of North Texas Wind Symphony follows a similar model to the military bands. Although clarinetists are not required to audition on bass clarinet at the University of North Texas, the section rotates all parts: principal, second, third, bass, and occasionally E-flat. Players are assigned parts and typically rotate between soprano and bass clarinet, or soprano and E-flat clarinet.

Other universities may hold auditions for bass clarinet, and students chosen for the position play bass clarinet for the year. Since there is not an established list of excerpts for bass clarinet in professional wind bands, the university audition lists are a valuable resource in determining which works are most demanding for bass clarinet. For example, Baylor University's audition list from 2014 for bass clarinet includes excerpts from movements 1, 2, and 3 of *First Suite in E-flat* (1909) by Gustav Holst, *Liberation* (2010) by David Maslanka, and *Dithyrambos* (2006) by Chang-Su Koh. Shown in Figure 10 is the excerpt from Holst's *First Suite in E-flat*, movement 2. A particular challenge for this excerpt is maintaining a lyrical quality while crossing the break of the instrument,

---

<sup>109</sup> Ibid.

meaning the player must move from E, or A, notes with little resistance, to B, or C, notes with the most resistance.

The excerpt shown in Figure 11 from Koh's *Dithyrambos* is a brisk tempo and requires the bass clarinetist to have the same kind of technical proficiency as the clarinetist. Developing technical facility on the bass clarinet is challenging since the instrument is larger, requiring a slightly different hand placement, and the keys of the instrument, particularly the pinky and thumb keys, require more force.

DePauw University chooses excerpts from *Sinfonietta* (1961) by Ingolf Dahl, and *Blue Shades* (1997) by Frank Ticheli, which features a jazz inspired bass clarinet solo that demands the bass clarinetist not only play in the jazz style, but also move with fluidity from the lowest register through the clarion, leaving no room for timid playing (see Figure 12).

Figure 10. Holst: First Suite in E-flat Movement 2<sup>110</sup>



Currently there is not an established list of excerpts for bass clarinet in band although these works are challenging enough to warrant extensive practice and study. As a result, Cheyenne Bland Cruz, assisted by Kimberly Cole Luevano and Henri Bok

<sup>110</sup> "Bass Clarinet – Baylor University," accessed April 22, 2015, <http://www.baylor.edu/content/services/document.php/228371.pdf>.



article focuses on excerpts from *La Fiesta Mexicana* by H. Owen Reed, *Blue Shades* by Frank Ticheli, and *First Symphony for Band* by William Bolcom. Cruz is a doctoral student at the University of North Texas and is currently working on her dissertation “The Bass Clarinetist’s Survival Guide: A Pedagogical Handbook to Excerpts from the Wind Band Literature.”

### Bass Clarinet Soloists

The earliest known bass clarinet performance took place in Stockholm in 1794 by Swedish clarinetist, Johann Ignaz Stranensky on Grenser’s 1793 bass clarinet.<sup>113</sup> Stranensky became a member of Stockholm’s Royal Theatre orchestra in 1791, mostly playing bass clarinet.<sup>114</sup> Also a composer, Stranensky wrote a concerto for clarinet (1806), a rondo for clarinet (1806), and a quintet for two clarinets, bassoon, and two horns.<sup>115</sup> Many previous reports indicate that the earliest bass clarinet performance was by “Ahl the younger” in 1809.<sup>116</sup> Little is known about Ahl, except for an 1815 publication of *Allgemeine musikalische Zeitung*, a German periodical of the time, which indicates that he was a clarinetist in the Mannheim orchestra who was known as “the darling of the public.”<sup>117</sup> Hoeprich notes a later report in the *Allgemeine musikalische Zeitung* from 1830, which describes a recital by Wilhelm Deichert and Conrad Bänder. The performance was in Kassel and the works performed were “Volkslied für Bass- un

---

<sup>113</sup> Albert Rice, “The Earliest Bass Clarinet Music (1794) and the Bass Clarinets by Heinrich and August Grenser,” *C.I.R.C.B. – International Bass Clarinet Research Center* (2010-2011): 1, accessed April 11, 2015,

[http://www.circb.info/sites/default/files/The%20earliest%20music%20for%20bass%20clarinet\\_0.pdf](http://www.circb.info/sites/default/files/The%20earliest%20music%20for%20bass%20clarinet_0.pdf).

<sup>114</sup> Pamela Weston, *Yesterday’s Clarinetists: A Sequel* (Yorkshire: Emerson Edition, Ltd., 2002), 165.

<sup>115</sup> *Ibid.*, 298.

<sup>116</sup> Rice, “The Earliest Bass Clarinet Music,” 6.

<sup>117</sup> Weston, *More Clarinet Virtuosi*, 25; Rice, *From the Clarinet d’Amour to the Contra Bass*, 340.

Contravass- Klarinette,” and an “Adagio mit variationen” on instruments made by Gottfried Streitwolf.<sup>118</sup>

Isaac Franco Dacosta was most known for re-designing Duma’s bass clarinet with L.A. Buffet and for his performance in *Les Huegonots*. He also gave a recital at Salle Saint-Jean de l’ Hotel-de-Ville in 1832, but no documentation of the repertoire he played has been found.<sup>119</sup> He studied clarinet at the Paris Conservatoire under Lefèvre, won first prize in 1798, and succeeded Lefèvre as clarinetist at the Grand Opera in 1825.<sup>120</sup>

Thomas Lindsey Willman (1784-1840) was a clarinetist who also played bass clarinet at a time when concertos were less popular and chamber music was in demand.<sup>121</sup> Although he was active during a time when few concertos were being written or performed, Willman still maintained a performing career. Highly praised by George Hogarth for his ability to perform obbligato accompaniment, Willman was most known for playing chamber works, especially those with voice.<sup>122</sup> While he did not specialize in bass clarinet, his abilities on the instrument were noteworthy, in particular, the first performance of “Make haste, O God” by Sigismund Neukomm on April 11, 1836, in which he accompanied Mrs. Alfred Shaw, a famous contra-alto, on a bass clarinet in C built by George Wood.<sup>123</sup> It is the first chamber work in which the bass clarinet was used to accompany the voice. The part has a range of three octaves and requires musical sensitivity and a technical command of the instrument.<sup>124</sup>

---

<sup>118</sup> Hoeplich, 373 (Endnote 37); Weston, *More Clarinet Virtuosi*, 80.

<sup>119</sup> Melissa Sunshine Simmons, “The Bass Clarinet Recital: The Impact of Josef Horák on Recital Repertoire for Bass Clarinet and Piano and a List of Original Works for that Instrumentation” (PhD diss., Northwestern University, 2009): 1.

<sup>120</sup> Weston, *More Clarinet Virtuosi*, 79.

<sup>121</sup> *Ibid.*, 270-71.

<sup>122</sup> *Ibid.*, 271.

<sup>123</sup> Weston, *More Clarinet Virtuosi*, 271-272.

<sup>124</sup> Rice, 272.

Werner Reinhart was an amateur clarinetist who financially supported several composers.<sup>125</sup> Most significant was Reinhart's support of Stravinsky's *Histoire du Soldat* (1918), which led to *Three Pieces* (1919) for solo clarinet dedicated to him by Stravinsky.<sup>126</sup> Other dedications include Arthur Honegger's *Sonatine* (1921), Paul Hindemith's *Clarinet Quintet Op. 30* (1923), and Ernst Krenek's *Kleine Suite Op. 28* (1923).<sup>127</sup> Two significant works for bass clarinet were composed for Reinhart; Othmar Schoeck's *Sonata Op. 41* (1928) and Adolf Busch's *Suite* for solo bass clarinet (1926).<sup>128</sup> Although the Schoeck's sonata was dedicated to Reinhart, he did not give the premiere performance. Instead, the premiere was given by Wilhelm Arnold on April 22, 1928.<sup>129</sup> Heaton describes the work as "the most important chamber work for bass clarinet from the first half of the twentieth century."<sup>130</sup>

In 1955, Josef Horák performed one of the most important bass clarinet recitals of the twentieth century.<sup>131</sup> In the lecture recital document "The Bass Clarinet Recital: The Impact of Josef Horák on Recital Repertoire for Bass Clarinet and Piano and a List of Original Works for That Instrumentation," Melissa Sunshine Simmons describes the first programmed recital, the lack of literature for bass clarinet in 1955, and the increase in works for solo bass clarinet since Horák's debut performance. The 1955 recital by Horák included two original compositions. First was Schoeck's *Sonata* for bass clarinet and piano, and the other was *Sketches* by Josef Masta, composed especially for Horák's 1955 recital. The rest of the recital consisted of transcriptions by "Girolamo Frescobaldi,

---

<sup>125</sup> Pamela Weston, *Yesterday's Clarinetists: a sequel* (Yorkshire: Emerson Edition Ltd., 2002), 135.

<sup>126</sup> *Ibid.*, 135.

<sup>127</sup> *Ibid.*, 135.

<sup>128</sup> *Ibid.*, 136; Heaton, *The Versatile Clarinet*, 93.

<sup>129</sup> Heaton, 93.

<sup>130</sup> Heaton, 93.

<sup>131</sup> Simmons, 2.

Benedetto Marcello, Jan Křtitel Vaňhal, Benjamin Godard, and Richard Wagner.”<sup>132</sup>

“Horák was the first bass clarinet specialist who no longer combined bass clarinet with B-flat clarinet,” and he is considered a pioneer in bass clarinet performance of avant-garde music.<sup>133</sup>

Shortly after Horák’s debut, Eric Dolphy was making headway as a jazz bass clarinetist. Known for his expressive playing, Dolphy began his career with the Chico Hamilton Quintet in Los Angeles and in 1960 moved to New York, joining the Charles Mingus group. Dolphy’s unique approach to jazz pushed the boundaries of bass clarinet playing. He explored the extreme range of the instrument, incorporated multi-phonics, and influenced bass clarinetists like Henri Bok and Harry Sparnaay. His bass clarinet albums include *What Love* (1964), Ornette Coleman’s *Free Jazz* (1961), and *Out to Lunch* (Blue Note Records, 1964). In 1964, at the age of 36, Dolphy died from a diabetic coma; however, the work he did changed the expectations of bass clarinet playing forever.<sup>134</sup>

Harry Sparnaay, another ground breaking bass clarinet soloist, began his career as an accordion player and saxophonist in his youth.<sup>135</sup> He switched to clarinet in order to attend the Amsterdam Conservatory where he studied with Ru Otto.<sup>136</sup> It was during this time that he heard and was inspired by the jazz recordings of Eric Dolphy and decided to pursue bass clarinet.<sup>137</sup> Much of Sparnaay’s career has been built from collaborating with composers such as Claudio Ambrosini, Luciano Berio, and Brian Ferneyhough, as well as

---

<sup>132</sup> Simmons, 3.

<sup>133</sup> Heaton, 94.

<sup>134</sup> Heaton, 64.

<sup>135</sup> Harry Sparnaay, Annelie de Man, and Paul Roe, *The Bass Clarinet: A Personal History* (Barcelona, Spain: Periferia Sheet Music, 2011), 12.

<sup>136</sup> Sparnaay, 14.

<sup>137</sup> *Ibid.*, 14.

instrumentalist such as pianist Polo de Haas, flautist Harrie Starreveld, and harpsichordist Annelie de Man, amongst others.<sup>138</sup> He was also Professor of Bass Clarinet and Contemporary Music at the Conservatoires of Amsterdam and Utrecht, and in 2011 published *The Bass Clarinet: A Personal History* about his life and experience as a performer of new music. This publication also serves as a guide for today's bass clarinetists interested in new music.<sup>139</sup>

Henri Bok is known for creating chamber ensembles of unique instrumentation such as bass clarinet and marimba/vibraphone, bass clarinet and accordion, and bass clarinet and oboe.<sup>140</sup> He has flourished in new music, and served as Professor of Bass Clarinet at Codarts/Rotterdam Superior Conservatoire (The Netherlands) and at Musikene (San Sabastian, Spain), as well as a guest professor at the Robert Schumann Hochschule für Musik (Düsseldorf, Germany).<sup>141</sup> In 1989 he wrote *New Techniques for the Bass Clarinet*.<sup>142</sup> The book includes information about clefs and notation, instructions for extended techniques, and a multi-phonic fingering chart. Bok initiated the first World Bass Clarinet Convention in 2005, and served as artistic director.<sup>143</sup>

Michael Lowenstern is one of the leading bass clarinetists at this time, and has performed with a variety of music ensembles including groups like the *Klezmatiks* and the *Orpheus Chamber Orchestra*.<sup>144</sup> As a composer, his interest in electronic music has allowed him to produce his own music such as *Spasm* (2013) and *Trip* (2013) for bass

---

<sup>138</sup> Harry Sparnaay, "Biography," accessed April 11, 2015, <http://www.harrysparnaay.info/biography.htm>.

<sup>139</sup> Ibid.

<sup>140</sup> Henri Bok, "About," accessed January 27, 2015, <http://www.henribok.com/#/about/4566067825>.

<sup>141</sup> Ibid.

<sup>142</sup> Henri Bok, *New Techniques for the Bass Clarinet* (Rotterdam: Henri Bok, 2005).

<sup>143</sup> Henri Bok, "About," accessed January 27, 2015, <http://www.henribok.com/#/about/4566067825>.

<sup>144</sup> Michael Lowenstern, "Biography," Manhattan School of Music, accessed January 27, 2015, <http://www.msmlnyc.edu/FacultyBio/FID/1019017296>.

clarinet and electronics.<sup>145</sup> Lowenstern supplies a wealth of knowledge to other bass clarinetists through his website “Earspasm.” The site includes a blog about issues specific to playing bass clarinet, and YouTube posts that range in topic from bass clarinet maintenance, selecting mouthpieces, dealing with reeds, to demonstrations of literature and orchestral excerpts.<sup>146</sup>

Lori Freedman is a freelance artist and composer based in Montreal who, in addition to bass clarinet, plays contrabass, A, B-flat and E-flat clarinets.<sup>147</sup> She works in a variety of arenas and does not limit herself to one style of music or to one type of ensemble. She has created her own group called Ensemble Transmission, a sextet that contains flute, clarinet, violin, cello, percussion and piano. Freedman has performed with the Grand Rapids, Kalamazoo, and Winnipeg Symphony Orchestras, and has expanded and promoted the literature for bass clarinet through performance of new music with chamber groups such as the wind quintet Fifth Species, the folk group Wyrd Sisters, and the sextet Ensemble Transmission, as well solo performances of her own compositions such as *The Anteater’s Parade* (2004) and *Brief Candles* (2006).<sup>148</sup>

Sarah Watts is another bass clarinetist of note who teaches bass clarinet at the Royal Northern College of Music and clarinet at Nottingham University. She and bassoonist Lawrence Perkins have started a four-day program on the Isle Rasaay in Scotland, which offers courses in bass clarinet taught by Watts, and courses in bassoon taught by Perkins.<sup>149</sup> The courses are open to all levels of bass clarinetists and focus on

---

<sup>145</sup> Michael Lowenstern, “Earspasm Music Shop,” accessed April 12, 2015, <http://earspasm.bandcamp.com/music>.

<sup>146</sup> Earspasm Music, accessed January 27, 2015, <http://www.earspasm.com/>.

<sup>147</sup> Lori Freedman, “Biography,” accessed January 27, 2015, <http://www.lorifreedman.com/en/apropos/>.

<sup>148</sup> Ibid., “Repertoire and Works,” accessed April 13, 2015, <http://www.lorifreedman.com/en/repertoire/compo/>.

<sup>149</sup> Sarah Watts, “Biography,” accessed January 27, 2015, [http://www.sarahkwatts.co.uk/Site\\_2/biog.html](http://www.sarahkwatts.co.uk/Site_2/biog.html).

improving all aspects of bass clarinet playing.<sup>150</sup> Kathryn Ladano specializes in bass clarinet, improvisation, and contemporary music. Ladano is currently the Artistic Director of NUMUS (Canada's New Music Organization), the co-Director of ICE (Improvisation Concerts Ensemble) at Wilfrid Laurier University, as well as the bass clarinet instructor at the University of Waterloo.<sup>151</sup> Members of the progressive bass clarinet quartet "Edmund Welles" are Cornelius Boots, Jeff Anderle, Aaron Novik and Jonathan Russell. The group creates their own music, inspired by rock and heavy metal, and an off-shoot of "Edmund Welles" is bass clarinet duo "Squonk," formed by Jeff Anderle, and Jonathan Russell.<sup>152</sup>

The increase in bass clarinet soloists also led to an increase in literature, and a growing interest in the instrument. Especially apparent is the need for musicians to be creative and diverse, not only by learning other instruments, but also by embracing all types of music and ensembles.

---

<sup>150</sup> Raasay Music Courses/Solo bass clarinet course, accessed April 15, 2015, [http://www.raasaymusiccourses.com/Raasaycourses/bass\\_clarinet\\_course.html](http://www.raasaymusiccourses.com/Raasaycourses/bass_clarinet_course.html).

<sup>151</sup> Kathryn Ladano, "About," accessed January 27, 2015, [http://kathrynladano.com/?page\\_id=43](http://kathrynladano.com/?page_id=43).

<sup>152</sup> Edmund Welles, "Bios," accessed January 27, 2015, <http://www.edmundwelles.com/about/>.

## Chapter 2

### Performance Issues and Model Programs of Study

#### Performance Issues for Bass Clarinet

The bass clarinet has its own set of obstacles that differ from the clarinet. Learning key placement, switching between soprano and bass, reading bass clef, and transposing bass clarinet parts in A are challenges musicians never face when playing soprano clarinet.

#### *Selmer and Buffet Low C Bass Clarinets*

This section is an overview of alterations in low C models by Selmer and Buffet from the 1960s to the present. Although Selmer and Buffet are not the only brands of low C bass clarinets available, they are the most widely used instruments in United States professional orchestras at this time. Both Selmer and Buffet were contacted by the author about design changes since the 1960s. Buffet is looking into the matter and Selmer stated that the design changes are confidential; therefore, the information in this text is gathered from method books, fingering charts and reviews published in *The Clarinet* by Clark Fobes.<sup>153</sup> Fobes is a mouthpiece and barrel maker located in San Francisco and submits reviews of instruments and equipment to *The Clarinet*. He has written several articles about bass clarinet mechanics and maintenance. Although many design changes are discussed here, students or professionals learning bass clarinet should spend some time

---

<sup>153</sup> Thierry Doublon, email message to author, September 29, 2014.

with his or her instrument in order to fully understand the key layout and tuning tendencies.

Extended range bass clarinets are now a necessity for musicians who want to perform in professional ensembles and as soloist. A standard bass clarinet extends to low E flat, but today's composers are writing works that utilize the lower notes, D, D flat, and C. Orchestral composers, such as Strauss and Wagner wrote for low C bass clarinets as well. Therefore it is in the clarinetist's best interest to purchase an instrument that extends to low C.

Brand new instruments can be expensive and clarinetists may resort to purchasing older, used models, or students may be playing older models owned by their school. The age, brand and model of a bass clarinet determine key placement and tuning tendencies of the instrument. In particular, professional bass clarinets with low C extensions have undergone several changes over a short period of time, and are still changing and improving to this day.

Buffet's first instrument with a permanent low C extension was manufactured in the 1920s, but production of these instruments ceased until 1931.<sup>154</sup> The model of the 1930s was also discontinued, however, Buffet began producing low C bass clarinets again in 1954, at which point the instrument continued to develop.<sup>155</sup> No fingering charts or diagrams for these early low C bass clarinets exist, or at least have not been discovered while researching this project. The first fingering diagram to include extended keys is from Henri Bok's book *New Techniques for Bass Clarinet* published in 1989 (see Figure 13).

---

<sup>154</sup> Kalina, Letter to the author, Feb. 21, 1969; July 10, 1969, by Jean Blondelot, 206.

<sup>155</sup> *Ibid.*, 206.

Figure 13. Henri Bok, Buffet Bass Clarinet Fingering Guide  
(© Henri Bok, 1989) Reprinted with permission from Henri Bok.

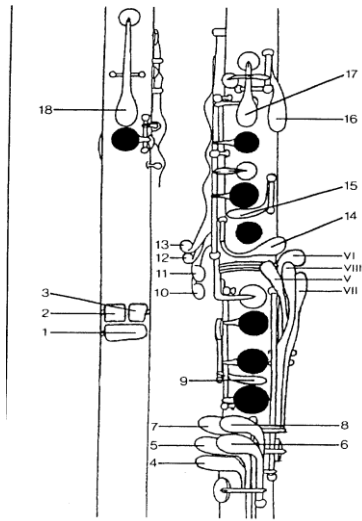

Extended keys are as follows:

Key 1 – Low C

Key 2 – Low C sharp

Key 3 – Low D

Key 4 – Low E flat

Although Buffet's BC1193 "Prestige" model bass clarinet was offered in the 1980s, it is the improved version of the 1990s that has become the standard for Buffet low C bass clarinets today. A 1995 post by Clark Fobes on woodwind.org describes his experience with Buffet bass clarinet from the 1980s through the 1990s.

For several years I was at a loss to recommend a good instrument. I had never been a fan of Buffet bass clarinets because of the short twelfths in the area of A/E2 - C1/G2. Also, the register mechanism of the Buffet bass clarinets is extraordinarily fickle. The initial offering of the "Prestige" Low C bass clarinets in the early 80's were a disappointment as well. I liked the sound, but the tuning schema was much too compromised.<sup>156</sup>

Although rarely purchased or used today, there is still the possibility that a clarinetist would have to work with an older instrument. This is an example of the challenges one would have to overcome when playing Buffet bass clarinets produced in the 1980s. Luckily, Buffet has ironed out several early design flaws as stated by Fobes.

At about the same time, [1990] though, Buffet began working more seriously on their bass clarinet design and I was sufficiently pleased that I began

<sup>156</sup> Clark Fobes, comment, July 1995, on "Bass Clarinets," woodwind.org, *The Clarinet Pages* (forum), accessed December 23, 2014, <http://www.woodwind.org/clarinet/Equipment/BassClarinets.html>.

recommending them. (My strongest "buy" recommendation was still for a good used pre-1983 Selmer.) The problematic twelfths still existed, but I liked the overall mechanism and sound. I made a trip to the Buffet factory in the summer of 1993 and brought up the problem. I was glad that they acknowledged the problem and said that they were working on it.<sup>157</sup>

From this statement one can determine that Buffet low C 1193 bass clarinets produced in the 1990s, particularly 1993, were of much higher quality although the exact changes that took place to improve the instrument are not identified. Fobes goes on to discuss the most recent models in 1995.

I am not certain when the design change took place, but VERY recent models of Buffet Low C bass clarinets are not only tuning better, but have a much more homogeneous sound. Rene Lesieux, the head acoustician at Buffet, has also recently incorporated some very interesting "resonance" keys into the design. I think Buffet clarinets can now be ordered with up to 6 different options "Mon Dieu!"<sup>158</sup>

It was the 1995 model that helped Buffet become one of the top competitors for professional low C instruments and, more recently, Fobes published a review of Buffet's current BC1193 "Prestige" bass clarinet in Volume 41, Issue 4, of the 2014 *Clarinet Journal*.

Buffet has been making the 1193 for at least 20 years, but over that time period there have been several changes; the present model was first produced ca. 2000 and is the most impressive iteration.<sup>159</sup>

Fobes goes on to discuss the pros and cons of this instrument, one of the most significant attributes being the curved neck which was originally designed by Charles Bay.<sup>160</sup> He notes that the key work is solid, but he has difficulty with the key arrangement fitting his hands. The clarity of the B-flat and the vent mechanism is very good on this

---

<sup>157</sup> Clark Fobes, comment, July 1995, on "Bass Clarinets," woodwind.org, *The Clarinet Pages* (forum), accessed December 23, 2014, <http://www.woodwind.org/clarinet/Equipment/BassClarinets.html>.

<sup>158</sup> Ibid.

<sup>159</sup> Clark Fobes, "Current Model Professional Low-C Bass Clarinets Available in the U.S.: A Review," *The Clarinet* 41, no. 4 (September 2014): 75.

<sup>160</sup> Ibid., 75.

instrument and, he notes that the extension keys are relatively easy to operate aside from the D being difficult to get to and “the tension was a bit too stiff.” Further improvements to the Buffet 1193 include the addition of adjustment screws to alter pad height, the low C-sharp tone hole, the robust tone in the low register, ease of playing in the altissimo register, and improved intonation.<sup>161</sup>

The following fingering chart from the second edition of *Bass Clarinet Quarter-tone Fingering Chart* by Jason Alder is based on the recent Buffet 1193 bass clarinet, and is a clear example of the key layout discussed in Fobes article (see Figure 14).<sup>162</sup>

Figure 14. Jason Alder, Buffet BC1193 “Prestige” Fingering guide  
(© Jason Alder, by permission)

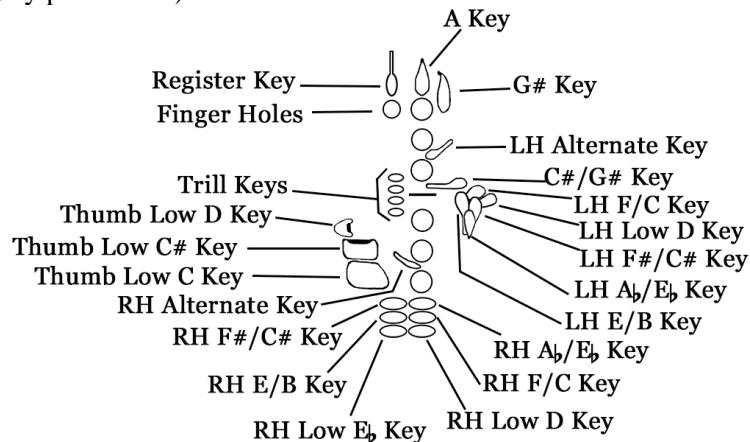

Since the 1989 guide by Henri Bok, several of the keys have been moved and altered, in particular the low register thumb keys, which are now stacked, wider, and include rollers.

<sup>161</sup> Clark Fobes, “Current Model Professional Low-C Bass Clarinets Available in the U.S.: A Review,” *The Clarinet* 41, no. 4 (September 2014): 75.

<sup>162</sup> Jason Adler, *Bass Clarinet Quarter-Tone Fingering Chart*, 2nd ed. (Jason Alder, 2009-2013).

In 2014 Buffet introduced the new *Tosca* BC1195 bass clarinet. Improvements to this instrument include a second vent key for a clearer sounding throat tone B flat which speaks more easily and is balanced with the C. This also allows the C (a usually sharp note) to play more in tune. A roller has been added to the bottom low C thumb key so that the player can trill from C to C sharp with ease. A common problem on older bass clarinets is key noise. To address this, the *Tosca* bass clarinet has “rubber dampers which are glued to the wood and absorb the sound from the keys.”<sup>163</sup> The new speaker key is adjustable and the key work is rounded like the *Tosca* clarinets. The thumb keys are in the same position as the 1193; however, the low D, normally played with the right hand thumb has been replaced with a low E flat.<sup>164</sup>

Selmer’s history is a bit different. It was not until 1930 that Selmer began producing bass clarinets with low C extensions. By the 1970s the Selmer model 33 was the low C bass clarinet of choice. While these instruments were the best at the time, it seems that it was quite common for professional bass clarinetists to invest in alterations to further improve the instrument. For example, Clark Fobes’s 1986 article dealt with fine tuning the Selmer model 33, focusing on the design before 1985 and offers solutions for the problems that these instruments had.<sup>165</sup> Models after 1985, included changes in key design and intonation which made playing the instrument more difficult, and this is why Fobes promotes the older models.

---

<sup>163</sup> Buffet, “Tosca Bass Clarinet,” (video) accessed December 2, 2014 <http://www.buffet-crampon.com/en/content/tosca-bass-clarinet> .

<sup>164</sup> Buffet-Crampon, “Tosca Bass Clarinet” (promotional video), 2014, accessed December 21, 2014, <http://www.buffet-crampon.com/en/content/tosca-bass-clarinet>.

<sup>165</sup> Clark Fobes, “Fine Tuning the Selmer Model 33 Bass Clarinet (Low C) Part I,” *Clarinet* 14, no. 1 (Winter 1986): 28.

Key noise and slow response are issues that have to be addressed in model 33 instruments before 1985. The keys were not always properly aligned at the factory, with too much height, creating more key noise.<sup>166</sup> Fobes suggests adjusting the key height and changing to higher quality pads that will ensure sufficient seal. He includes a chart with specific measurements for key and pad height, and also a list of keys that can have corks added for quiet action.

Another problem with the Selmer model 33 prior to 1985 is the placement and construction of the three thumb keys. These keys were originally far to the left, and difficult to reach and maneuver. Also, these keys are tear drop shaped and do not have the rollers that modern bass clarinets have. In his article about fine tuning the Selmer Model 33, Fobes states:

The solution to facile movement in this area has yet to be adequately addressed by any manufacturer—even in new models. However, the existing three-key system of the model 33 prior to 1985 can be simply altered to allow diatonic movement from D-C (see Figure 15).<sup>167</sup>

Figure 15. Clark Fobes, Selmer Model 33 – back three thumb keys with adjustment  
Reprinted with permission from Clark Fobes.

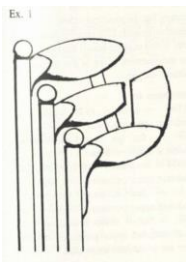

The Selmer model 33 after 1985 had only two keys. Fobes does not address this, but only points out that models produced before 1985 had three keys. Henri Bok's

---

<sup>166</sup> Fobes, "Fine Tuning the Selmer Model 33 Part I," 28.

<sup>167</sup> Clark Fobes, "Fine Tuning the Selmer Model 33 Bass Clarinet (Low C) Part I," *Clarinet* 14, no. 1 (Winter 1986), 28.

fingering chart from 1989, includes two diagrams of Selmer bass clarinets (see Figure 16). Bok does not indicate a year of production or different models for the diagram, but since the Selmer model 37 was not available until 1995, the bass clarinet depicted with two thumb keys must be a Selmer model 33 produced after 1985.<sup>168</sup> Finally, I own a Selmer low C bass clarinet from 1992 which is identical to the new model in Henri Bok's book. Selmer provided the year and model of my instrument based on the serial number, concluding that it was the model 22, which is sold as the model 33 in the US. My instrument had already undergone pad and key alignment adjustments when purchased, solving the intonation issues. In comparison to newer models, the extended range is more difficult to play, but manageable. Fobes stated in 1995 on woodwinds.org that "in the last two years Selmer has made some refinements in the intonation of the model '33' that has really moved them ahead of the pack."<sup>169</sup>

Fobes continues with advice about tuning tendencies of the instrument, particularly pointing out the notoriously sharp middle line B. He advises to begin tuning the instrument in the throat tones so as to properly adjust the pitch for the neck. His second article about fine tuning the Selmer model 33 is published in *The Clarinet*, Volume 4, Issue 2, and focuses on adjusting the very fickle register key.<sup>170</sup> Ultimately, it is a good idea for anyone who owns an older bass clarinet to always travel with a set of screwdrivers.<sup>171</sup>

---

<sup>168</sup> Clark Fobes, comment, July 1995, on "Bass Clarinets," woodwind.org, *The Clarinet Pages* (forum), accessed December 24, 2014, <http://www.woodwind.org/clarinet/Equipment/BassClarinets.html>.

<sup>169</sup> Ibid.

<sup>170</sup> Clark Fobes, "Fine Tuning the Selmer Model 33 Bass Clarinet (Low C)," *Clarinet* 14, no. 2 (Winter 1987).

<sup>171</sup> Ibid., 20.

Figure 16. Henri Bok, Selmer key positions  
 from *New Techniques for the Bass Clarinet* (© Henri Bok, 1989) Reprinted with permission from Henri Bok.

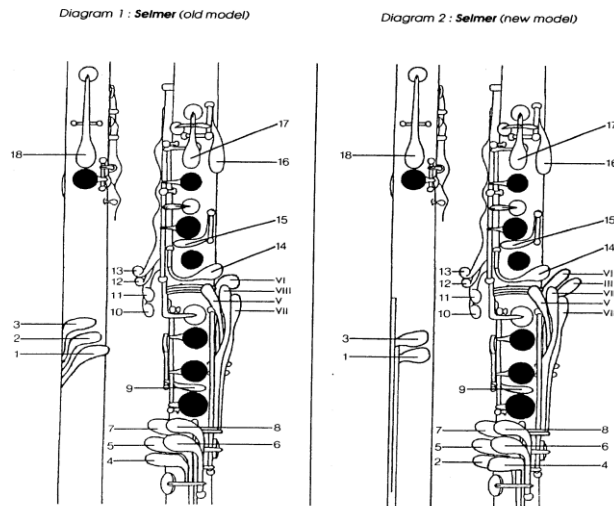

Extended keys are as follows:

Old Model (pictured left)	New Model (pictured right)
Key 1 – low C	Key 1 – Low C
Key 2 – low C sharp	Key 2 (located in the outside right pinky) – Low C sharp
Key 3 – low D	Key 3 – Low D
Key 4 – Low E flat	Key 4 (located on the inside right pinky) – Low E flat

It was 1995 when Selmer came out with the model 37.<sup>172</sup> In my research, I was able to find out very little with regard to changes in mechanism, tuning and key work.

The only documented changes found are from Clark Fobes 1995 posting on woodwinds.org as follows:

The Model 37 has the improved intonation of the last “33’s” and some excellent redesign in the mechanism. The extension mechanism has been simplified and the formerly weak right hand linkages have been reinforced and feel very positive. The only flaw that I have noticed so far is that the lowest E is very flat. The tone is robust and has an excellent core. In fact, I prefer the sound in the upper clarion

<sup>172</sup> Clark Fobes, comment, July 1995, on “Bass Clarinets,” woodwind.org, *The Clarinet Pages* (forum), accessed December 24, 2014, <http://www.woodwind.org/clarinet/Equipment/BassClarinets.html>.

to my beautiful 1976 Selmer 33. I have not had a chance to play one extensively, but overall my impressions are excellent!<sup>173</sup>

The most current low C model of bass clarinet that Selmer has produced is model 67 Privilege, which was first introduced in 2004.<sup>174</sup> According to Clark Fobes’s review of the instrument in Volume 41, Issue 2 of the *The Clarinet*, Selmer model 67 is of the highest quality.<sup>175</sup> The new Selmer 67 offers two neck types so that the clarinetist can choose which works best for his or her instrument. The keys have been relocated and adjusted so that it is easier to play technically challenging passages. The left hand spatula and extension keys have been redesigned so that movement between keys is fluid and easy. These new instruments also include a thumb E-flat key. Fobes notes that although the bass clarinet frequently goes out of adjustment, there are multiple adjustment screws. The intonation is much better than in the past although it has lost some robustness to the sound.<sup>176</sup>

Table 1. Timeline of Changes: Buffet and Selmer Bass Clarinets

<b>Selmer</b>	<b>Buffet</b>
	1920s Buffet produces low C bass clarinets but ceases production.
1930s Selmer begins producing low C bass clarinets.	1931 Buffet produces low C bass clarinet but ceases productions
	1954 Buffet produces low C bass clarinets and continues production.
1970s Selmer model 33	
1980s Selmer alters model 33	
1995 Selmer model 37	1995 Buffet 1193 “Prestige”
2004 Selmer “Privilege” model 67	2000 Modifications to Buffet 1193
	2013 Buffet Prestige Greenline
	2014 Buffet 1195 Tosca

<sup>173</sup> Ibid.

<sup>174</sup> Selmer France/Selmer Privilege B-flat Bass Clarinet, accessed December 24, 2014, <http://www.selmer.fr/fiche.php?code=1108045011>.

<sup>175</sup> Clark Fobes, “Current Model Professional Low-C Bass Clarinets Available in the U.S. – A Review,” *Clarinet* 41, no. 4 (September 2014): 74.

<sup>176</sup> Ibid., 74.

### *Clefs, Notation, and Transposition*

Unlike the clarinet which is only written in treble clef, bass clarinet parts can be written in treble clef, bass clef, and, in the case of early music, tenor clef. The rules for reading these clefs can vary depending on whether the bass clarinetist is reading in French or German notation and the time period in which the piece was composed. This type of notation is briefly explained in Kroll's *Clarinet*, Rendall's *Clarinet*, Hoepfich's *The Clarinet*, and Rice's *From the Clarinet D'Amore to the Contrabass: A History of Large Size Clarinets 1740-1860*.<sup>177</sup> The method books by Henri Bok and Harry Sparnaay describe how this notation works in-depth. Bok includes a brief paragraph describing how the types of notation work and his description is very clear for any reader to understand. Harry Sparnaay goes into more depth, and includes examples for each type of notation, creating a guide that is clear and very easy to relate to music.

French notation is in treble clef and is read the same way that a clarinetist would read clarinet music. Since the bass clarinet sounds an octave lower than the B-flat soprano clarinet, the bass clarinet will sound a major 9<sup>th</sup> lower than the written note in French notation. This type of notation is preferred by clarinetists switching to bass clarinet because the fingerings do not change.<sup>178</sup>

German notation is typically in bass clef. This is the actual range of the bass clarinet, and since the bass clarinet is a B-flat instrument, it sounds a major second lower than the written note. Sometimes parts in German notation are composed in treble clef to eliminate ledger lines. In this instance the rules of German notation still apply so that the

---

<sup>177</sup> Albert Rice, *From the Clarinet d'Amour to the Contra Bass: A History of Large Size Clarinets, 1740-1860* (New York: Oxford University Press, 2009).

<sup>178</sup> Sparnaay, *The Bass Clarinet: A Personal History*, 40; Henri Bok, *New Techniques for the Bass Clarinet*, 4.

bass clarinet sounds a major second lower than the written note. Therefore, in German notation, the bass clarinetist must play treble clef parts an octave higher than they would in French notation.<sup>179</sup>

While it is less common in solo and chamber music, some composers, such as Stravinsky, merge the two types of notation. In this instance the bass clarinet sounds a major second lower when in bass clef, but in treble clef, the bass clarinet sounds a major ninth lower. Therefore, when bass clarinetists read mixed notation, the rules of German notation apply to sections in bass clef, but the rules of French notation apply to sections in treble clef. Modern orchestral excerpt books, such as Michael Drapkin's *Symphonic Repertoire for the Bass Clarinet*, Volumes 1-3, indicate whether the composer uses French, German, or a mixture of both notations.<sup>180</sup>

Although it is not often used, Sparnaay discusses a fourth type of notation that he calls "The really 'Bad' Notation." This type of notation is French notation composed in bass clef so that all notes sound an octave and a major second lower. This type of notation would most likely be found in modern works.

Early music for bass clarinet sometimes includes the tenor clef. Composers used this clef so that there would be fewer ledger lines, and to indicate that the instrument should be in B-flat. When reading tenor clef, notes sound an octave higher than written. This is most often seen in opera compositions by Mercedante, Donizetti, and Verdi.<sup>181</sup>

Bass clarinet parts in orchestra are occasionally composed in A and C (see Table 2). In such situations these parts may be in bass clef as well. Transposing, reading in

---

<sup>179</sup> Sparnaay, 42; Bok, 4.

<sup>180</sup> Michael Drapkin, *Symphonic Repertoire for the Bass Clarinet*, vols. 1-3 (Glenmore: Roncorp Publications, 1979-2004).

<sup>181</sup> Rice, 342.

treble and bass clef, and switching from one instrument to the other are skills that must be developed by bass clarinetists.

Table 2. Orchestral Excerpts with German Notation, Mixed Notation, Transposition.

<b>Composer</b>	<b>Title</b>	<b>Year</b>	<b>Transposition/Notation</b>
Bartók	<i>The Miraculous Mandarin</i>	1919	Bass Clarinet in A and B- flat
Bartók	<i>Violin Concerto No. 2</i>	1938	Bass Clarinet in A and B- flat
Bloch	<i>Schelomo: Hebraic Rhapsody for Cello and Orchestra</i>	1916	German notation
Chadwick	<i>Symphonic Sketches</i>	1908	German notation
Copland	<i>El Salón México</i>	1936	German notation
Dukas	<i>The Sorcerer's Apprentice</i>	1987	German notation
Dvořák	<i>The Wild Dove</i>	1896	Bass Clarinet in A and B-flat
Franck	<i>Psyché et Éros</i>	1908	German notation
Khachaturian	<i>Piano Concerto</i>	1946	German notation
Janáček	<i>Sinfonietta</i>	1926	German Notation
Mahler	<i>Das Lied von der Erde</i>	1908	Bass Clarinet in A and B-flat
Mahler	Symphony No. 4	1900	Bass Clarinet in A and B-flat
Mahler	Symphony No. 6	1904	Bass Clarinet in A and B-flat
Mahler	Symphony No. 7	1905	Bass Clarinet in A and B-flat
Mahler	Symphony No. 8	1907	Bass Clarinet in A and B-flat
Prokofiev	<i>Romeo &amp; Juliet Suite No. 2</i>	1936	German notation
Prokofiev	Symphony No. 5	1944	German notation
Rachmaninoff	<i>Symphonic Dances</i>	1941	Bass Clarinet in A and B-flat/mixed notation
Rachmaninoff	Symphony No. 2 in E Minor	1907	Bass Clarinet in A and B-flat, mixed notation
Rachmaninoff	Symphony No. 3 in A Minor	1936	Bass Clarinet in A and B- flat, mixed notation
Ravel	<i>Concerto for the Left Hand</i>	1930	Bass Clarinet in A and B-flat
Ravel	<i>L'Enfant et les Sortilèges</i>	1925	Bass Clarinet in A and B-flat
Ravel	<i>La Valse</i>	1920	Bass Clarinet in A and B-flat
Ravel	<i>Rapsodie Espagnole</i>	1908	Bass Clarinet in A and B-flat
Respighi	<i>The Pines of Rome</i>	1924	Bass Clarinet in A and B-flat
Shostakovich	<i>Violin Concerto</i>	1957	German notation
Shostakovich	Symphony No. 4	1935-36	German notation
Shostakovich	Symphony No. 6	1939	German notation
Shostakovich	Symphony No. 8 in C Minor	1943	German notation
Stravinsky	<i>Petroushka</i>	1911	Mixed notation
		version	
Stravinsky	<i>The Rite of Spring</i>	1913	Mixed notation

Most books about bass clarinet history and literature include explanations of clefs for bass clarinetists; however, the clef discrepancy is not discussed in all orchestration

textbooks. For example, Cecil Forsyth’s book *Orchestration* gives a clear example of how the bass clarinet can play in both treble and bass clef while Berlioz’s treatise on orchestration and Strauss’s revision both fail to mention German notation and only discuss composing for the bass clarinet in French notation.<sup>182</sup> In his book *The Bass Clarinet: A Personal History*, Harry Sparnaay gives a very clear explanation of clefs for bass clarinet by incorporating musical examples to show how clef changes work.

### *Extended Techniques and Extended Range*

Learning extended techniques is critical for today’s bass clarinetist since it is often required in modern literature. Extended techniques include slap tongue, flutter tongue, multi-phonics and playing in the extreme range of the instrument. Multi-phonics require specific voicings and fingerings so that the instrument produces more than one note at once. Also, the bass clarinet has the capability of playing in the altissimo range and beyond. The range an octave above altissimo C is called the “extremely-high range” and is typically notated as *8va* above altissimo notes. Harry Sparnaay’s book *The Bass Clarinet: A Personal History* and Henri Bok’s *New Techniques for Bass Clarinet* are guides to extended techniques and include fingering charts for multi-phonics and the extremely-high range (see Figure 17).

Figure 17. The High and Extremely-high Range



<sup>182</sup> Cecil Forsyth, *Orchestration* (New York: MacMillan, 1944), 273-274; Berlioz, rev. Strauss, 222.

### *Switching from Soprano to Bass Clarinet*

Switching between soprano and bass clarinet, sometimes with only a few measures to make the transition between instruments, is a necessary skill with several challenges, especially when playing second and third orchestral parts. Aside from orchestral works, today's composers are writing chamber music that often requires clarinetists to play both instruments, if not the entire clarinet family. Also, in the twenty-first century there is more solo literature that exists for double on clarinet and bass clarinet. Transitioning from soprano to bass clarinet requires embouchure changes, changes in resistance from one instrument to another, and changes in voicing from the soprano clarinet. As a clarinetist, approaching the bass clarinet for the first time has several obstacles to overcome. The following section outlines the issues faced and offers solutions for musicians.

### *Embouchure, Air Support, and Voicing*

When discussing embouchure, there is often a fear that playing bass clarinet will create problems (usually an embouchure that is too loose) for soprano clarinet. On the contrary, there are enough similar characteristics between the two that the change should not be drastic enough to create problems for clarinet embouchure. Producing a quality sound on bass clarinet follows many of the same principles as playing soprano, and if one has a solid, fundamental embouchure when playing soprano, the bass clarinet will only build on this skill set.

Clarinetists playing bass clarinet for the first time often learn from trial and error. In comparison to the numerous books and articles written about clarinet pedagogy, there

is little written for bass clarinet. Thanks to bass clarinetists like Josef Horák, Henri Bok, and Harry Sparnaay, there has been growth in bass clarinet performance and pedagogy. Aside from these publications, Lawrie Bloom, Edward Palanker, and Paula Corley have each contributed articles with regard to bass clarinet fundamentals.

Lawrie Bloom, bass clarinetist for the Chicago Symphony and Assistant Professor of Clarinet at Northwestern University, published an article, “Developing Facility on the Bass Clarinet” in *The Woodwind Player’s Cookbook*. Bloom has also constructed a series of YouTube videos about playing bass clarinet. His approach to switching is simple, direct and positive. The most important point, in both the videos and article, is for clarinetists not to focus on the differences involved in playing bass clarinet, but on the similarities between soprano and bass. The bass clarinet is a member of the clarinet family, and while it is a different instrument, it is not completely foreign and the experience from playing clarinet should transfer. With this concept, the bass clarinet embouchure is similar to soprano in that pressure comes from the upper lip and sides, while the lower jaw is more relaxed. Bloom points out that often clarinetists are afraid to play bass clarinet because they feel it may disrupt their embouchure, hand position, air support etc. On the contrary, “it is impossible to play the bass with tension.”<sup>183</sup> Overall, bass clarinet positively affects clarinet and vice versa.

Another note-worthy bass clarinetist is Edward Palanker, bass clarinetist and clarinetist with the Baltimore Symphony. He has published a series of articles addressing various topics for bass clarinet performance. In his article “Bass Clarinet 101, Bass

---

<sup>183</sup> Lawrie Bloom, “Developing Facility on the Bass Clarinet,” *The Woodwind Player’s Cookbook* (Gatesville: Hall Leonard, 2008), 12-14.

Clarinet for Dummies” published in Volume 31, no. 4 of *The Clarinet*, Palanker discusses his approach to the bass clarinet. With regard to embouchure he writes:

I believe in a soft embouchure, not loose but not rigid. The jaw and sides of the mouth should be firm but relaxed as well. The only pressure should be the top teeth and top lip holding firmly on the mouthpiece but remaining relaxed at the same time. This secures the mouthpiece from moving about and enables the lower lip to be somewhat relaxed and flexible so it can wrap comfortably around the reed. Project the embouchure in a forward direction as if you are blowing out a candle or whistling, but not to that extreme. This will eliminate the unneeded tension of blowing in one direction and holding the muscles in the opposite direction. Folding the top lip into the top teeth will enable you to get a slightly bigger, more open tone, simulating a double lip without the teeth cutting into the lip. This will also enable you to open your throat more. Although the lower lip should remain reasonably stationary, you need to be a bit flexible in “rolling” the teeth slightly when skipping from the upper register to the lower register while voicing the back of the throat low.<sup>184</sup>

Palanker’s explanation of bass clarinet embouchure is very detailed, yet still has the same underlying principles as soprano clarinet. There are enough similarities between the two embouchures to make the transition easier.

There are similar views across the board with regard to bass clarinet embouchure, and Paula Corley’s interview with Howard Klug, Michael Drapkin, and Alcides Rodriguez is an excellent example. When asked the question “is the Bass Clarinet embouchure more similar or more different when compared to B-flat soprano?” each replied with similar answers.

---

<sup>184</sup> Edward Palanker, “Bass Clarinet 101: Bass Clarinet for Dummies,” *The Clarinet* 31, no. 4 (September, 2004): 79-80.

Articles<sup>185</sup>

Klug: It is, indeed, very similar to the soprano embouchure, but it has a more rounded/circular grip with a less aggressive bite. Most young ‘switchers’ to bass clarinet also need to be encouraged to take in more mouthpiece which, when done properly, gets a large tone that speaks more easily. The embouchure grip is a gentler hold than the one on soprano B-flat, and one can get away with less insistence on a flat/pointed chin.

Drapkin: The bass clarinet embouchure is a larger variant of the soprano clarinet embouchure. It is larger, and needs to accommodate the robust lower register which functions and is orchestrated in the bass range, while the upper tenor range plaintively follows the characteristic clear tone of the soprano clarinet, only with greater depth. It is preferable to approach bass the same as the soprano clarinet. It is therefore not unusual that most of the great bass clarinetists are also great soprano clarinet players as well.

Rodriguez: I believe the bass clarinet embouchure should be formed exactly like that for the clarinet with a few minor differences. Since the size of the mouthpiece and the reed is larger, you will have to take in more mouthpiece. The bottom lip should sit further down on the reed than it does on clarinet. The embouchure should be slightly more open than on the clarinet. The pressure applied to the reed is not the same as on the clarinet. Too much pressure on a bass clarinet reed will cause it will not to vibrate. The bottom lip should be more relaxed, while keeping the shape of the chin.

In general, bass clarinet embouchure is different, but not completely different, so transitioning from one instrument to the other is not entirely foreign to the clarinetist.

Proper air support on any instrument is vital to all areas of playing, in particular, articulation and voicing. There should be little alteration in breath due to the size of the instrument, the intake of air should be calm and relaxed, and the fundamental air column remains the same from soprano to bass. The principles of voicing for bass clarinet are similar to the clarinet, but change slightly between the two instruments. For example,

---

<sup>185</sup> Paula Corley, “Bass Clarinet 101: Tips for Improving your Bass Clarinet Section, A Conversation with Howard Klug, Michael Drapkin and Alcides Rodriguez,” accessed January 21, 2015, <http://dansr.com/vandoren/articles/115/bass-clarinet-101-tips-for-improving-your-bass-clarinet-section-a-conversation-with-howard-klug-michael-drapkin-amp-alcides-rodriguez>.

when voicing the lowest notes (chalumeau G and below) on clarinet, it is best to use an “ahh” syllable. These notes on bass clarinet sound an octave lower and the “ahh” becomes more open so that the notes speak clearly. When voicing notes in the clarion and altissimo range on soprano clarinet, it is best to use a “eh,” “ee,” or “hee” syllable. This same approach carries over to the bass clarinet, with slight adjustments that coincide with the tendencies of the instrument.

With regard to breath support, Bloom points out that students and professionals often overblow the instrument at first. This is a result of misconceptions associated with the size of the bass clarinet, mouthpiece, and reed. While the bass clarinet is larger, it only requires a bit more air than the soprano clarinet. The reed is larger, but weaker, requiring less pressure than soprano reeds, and the mouthpiece opening is only slightly wider than soprano. Bloom also recommends that every bass clarinetist learn the resistance points of his or her instrument and adjust accordingly. Strauss tone poems and Bach cello suites are recommended to test resistance.

Edward Palanker writes that the clarinetist “should not approach the bass clarinet as if it were a clarinet. There are similarities but there are differences also.”<sup>186</sup> Breath support is one similarity. Palanker states that “The same principles apply to the bass clarinet as to any other wind instrument; it just requires more air than a clarinet.”<sup>187</sup> In this section, he also discusses tonguing. The player should use the tip of the tongue with a light stroke, just as on the clarinet. With regard to voicing, he points out that if the tongue is too high, the tone will become small. Voicing should happen toward the back of the tongue and not as close to the front as clarinet.

---

<sup>186</sup> Edward Palanker, “Bass Clarinet 101: Bass Clarinet for Dummies,” *The Clarinet* 31, no. 4 (September, 2004): 79-80.

<sup>187</sup> Ibid.

In the DANSR interview there are no direct questions about voicing and air support, but both Howard Klug and Alcides Rodriguez address these topics when asked “what is your best piece of advice for achieving success on bass clarinet?”<sup>188</sup>

Howard Klug: The blowing resistance on a bass clarinet increases significantly around F/G/A in the 2<sup>nd</sup> register. Typically, young players unconsciously drop their tongues and open their throats in response to this increased resistance. This creates big problems for the response and security of these notes, causing a sluggish/fuzzy tone and making staccato notes a virtual impossibility. Even starting a phrase on those notes can be difficult. Encourage a cold air, high tongue E for the mouth cavity voicing, and spend some time jumping 12ths from the chalumeau register to these notes WHILE HOLDING the chalumeau register mouth cavity. Assist the student in re-learning the second register voicing by having them play a forte C below the staff. Once that note is established, the teacher can activate the register key (without the student anticipating this action)—and a secure G above the staff will usually leap out. The student can then try various left hand 12th intervals (C/G, D/A, E/B) by opening the register key with the thumb of the RIGHT hand. This approach generally teaches the student to maintain the same mouth cavity for the upper notes, thereby increasing their security. Learn from the lower register to teach the upper register.

Alcides Rodriguez: Approach the bass clarinet as an instrument with its own voice. The bass clarinet should sound like a bass clarinet and not like a clarinet played one octave lower. Apply the same sound concept as for clarinet, (round sound and evenness throughout the entire register.) Always think about the unique sound of the bass clarinet. Accomplish things on the bass clarinet in the same manner as on the soprano clarinet. Enjoy the things that the bass clarinet can do that the soprano clarinet cannot, and have fun with it.

When switching between bass and soprano, the focus should be on the similarities between the two instruments while still being aware of the differences. Also, it is important that the clarinetist practice switching. This will help the clarinetist to be comfortable on both instruments, allowing for quick, smooth transitions.

Brian Ebert wrote an excellent dissertation, “Integrated Exercises for Clarinet and Bass Clarinet,” about doubling on clarinet and bass clarinet.<sup>189</sup> His research reveals the

---

<sup>188</sup> Paula Corley, DANSR Interview, accessed January 20, 2015, <http://dansr.com/vandoren/articles/115/bass-clarinet-101-tips-for-improving-your-bass-clarinet-section-a-conversation-with-howard-klug-michael-drapkin-amp-alcides-rodriguez>.

importance of doubling and highlights the fact that there is no standard pedagogy for bass clarinet in the studio, leaving bass clarinetists to come up with their own solutions for the problems discussed above. Ebert's dissertation not only includes a section about the importance of doubling for musicians today, but features a series of studies he has designed for clarinetists learning to play bass clarinet on their own. His workbook can be modified to suit each person and it is an excellent source that should be incorporated into the studio. Other than this workbook, I have found no other studies that incorporate switching between bass and soprano.

#### University Programs that Serve as Models for the Suggested Curriculum

Programs that offer specialization in bass clarinet or include the study of auxiliary clarinets, are models that serve as the basis for the suggested course of study in Chapter 4. Other programs that do not include bass clarinet but were also considered as models are those programs that offer multiple woodwinds degrees and programs that offer only studies in traditional clarinet literature and performance.

These programs demonstrate three critical points: (1) the bass clarinet is an instrument that requires special teaching and study, (2) there is enough demand for bass clarinet performance and enough demanding literature to support specialized study of the instrument, and (3) a core of literature has yet to be fully established.

---

<sup>189</sup> Brian Ebert, "Integrated Exercises for Clarinet and Bass Clarinet" (DMA diss., University of Northern Colorado, 2012).

## *Programs with Specialization in Bass Clarinet*

### *Conservatorium von Amsterdam, Amsterdam School of the Arts*

The Amsterdam School of the Arts offers bachelor's and master's degrees in bass clarinet. All students in the undergraduate program must complete an introductory, or "propaedeutic," year in which certain criteria are set. If the criteria, or areas of competency, are not met over the course of the year, then students may not continue studies at the conservatory. The three areas of competency that all music students must achieve when attending the conservatory are as follows: (1) Artistic Competence, (2) Technical Competence, and (3) Professional and Social Competence.<sup>190</sup> Within each area of competence are other criteria to be met. For instance, students who demonstrate artistic competence must show "vision and creativity, the ability to communicate and the ability to collaborate."<sup>191</sup> Technical competence involves the ability to maintain various techniques and "analytical ability" while Professional and Social Competence requires that students have "contextual focus," "entrepreneurship," "innovation," "a professional, methodical approach" to performance, and "possess didactic and methodical knowledge."<sup>192</sup> Harry Sparnaay, who taught students such as Lori Feedman and Michael Lowmstern, began his studies at the conservatorium with Ru Otto.<sup>193</sup> The influence of Sparnaay, and the success of bass clarinetists who have attended the conservatorium, has

---

<sup>190</sup> "Classical Music Study Guide Bachelor's Degree Programme 2014-2015," accessed January 17, 2015, <http://www.ahk.nl/fileadmin/download/conservatorium/studiegids/StudiegidsBachelorKlassiek2014-2015-eng.pdf>, 6.

<sup>191</sup> *Ibid.*, 6.

<sup>192</sup> "Classical Music Study Guide Bachelor's Degree Programme 2014-2015," accessed January 17, 2015, <http://www.ahk.nl/fileadmin/download/conservatorium/studiegids/StudiegidsBachelorKlassiek2014-2015-eng.pdf>, 7.

<sup>193</sup> Sparnaay, 15; Lori Freedman, "An Abridged Chronology by Bryce Canyon in 2004," accessed January 17, 2015, <http://www.lorifreedman.com/en/apropos/chrono/>; "Michael Lowmstern, Artist's Biography," accessed January 17, 2015, <http://www.conn-selmer.com/en-us/artist-information/centerstage/artist-roster/michael-lowmstern/>.

made it a hub for bass clarinetistry. Table 3 provides the exact layout of the course for bass clarinet found on the conservatory website.

Table 3. Amsterdam Conservatory Course Description: Bachelor's Degree in Bass Clarinet<sup>194</sup>

<b>Amsterdam Conservatory Course Description: Bachelor's Degree in Bass Clarinet</b>	
Bachelor's Degree in Bass Clarinet:	"Apart from principal-study tuition, teachers also organize group lessons (including for instance repertoire classes for flutists). Students take orchestral classes. Furthermore, workshops and masterclasses are organized regularly by the various principal-study sections. Apart from orchestral projects, there are special projects for wind players and chamber music." <sup>195</sup>
Overview of lessons and requirements related to the principal subject: This is a multifaceted programme which incorporates as many aspects of the profession as possible.	
First Year/Propaedeutic Year [introductory year]	<ul style="list-style-type: none"> <li>- weekly principal private lessons</li> <li>- wind ensemble</li> <li>- ensemble skills with co-répétiteur; students will preferably have their own pianists because of the repertoire</li> <li>- forming a bass clarinet-piano duo</li> <li>- propaedeutic examination lasting approximately 20 minutes. Repertoire: one étude and two concert pieces</li> </ul>
Second year	<p>Please see first year.</p> <ul style="list-style-type: none"> <li>- principal private lessons</li> <li>- chamber-music lessons taught by the chamber-music teachers</li> <li>- playing in the contemporary music ensemble</li> <li>- studying several works for bass clarinet and tape</li> <li>- methodology classes</li> <li>- end-of-year examination lasting 20 minutes. Repertoire: étude and two concert pieces, one of which [is] with tape</li> </ul>
Third year	<p>Please see first year.</p> <ul style="list-style-type: none"> <li>- principal private lessons</li> <li>- chamber-music lessons</li> <li>- contemporary music ensemble</li> <li>- forming a flute, bass clarinet and piano trio</li> <li>- score study</li> <li>- evening group recitals</li> <li>- methodology classes and internships, including final paper in May/June</li> <li>- end-of-year examination lasting 20 minutes</li> </ul>
Fourth year	<ul style="list-style-type: none"> <li>- principal private lessons</li> <li>- chamber music, e.g. bass clarinet and string quartet</li> <li>- contemporary music ensemble</li> <li>- orchestra projects</li> <li>- evening group recitals and lunchtime concert(s)</li> <li>- final examination lasting 50 minutes. Repertoire: works of various instrumentation, including one with tape</li> </ul> <p>Third- and fourth-year 'free space' electives Please see the general selection of electives in the electives programme.</p>
Teacher: Erik van Deuren + methodology	
Admission requirements:	<ul style="list-style-type: none"> <li>- etudes (both staccato and legato) to be chosen from the following: A. Uhl part I; W.F. Bon</li> <li>- pieces with piano: Rob du Bois - Fusion pour deux; Othmar Schoeck - Sonate; Paul Hindemith - Sonate (bassoon)</li> <li>- minor and major scales up to and including three sharps and three flats with triads</li> </ul>

<sup>194</sup> "Classical Music Study Guide Bachelor's Degree Programme, 2014-2015," accessed January 17, 2015, <http://www.ahk.nl/fileadmin/download/conservatorium/studiegids/StudiegidsBachelorKlassiek2014-2015-eng.pdf>, 45.

<sup>195</sup> "Conservatorium von Amsterdam/Bachelor's Degree in Bass Clarinet," accessed January 17, 2015, <http://www.ahk.nl/en/conservatorium/study-programmes/bachelor/bachelor-classical-music/woodwinds/bass-clarinet/>.

The course of study at the undergraduate level emphasizes chamber music, performing with various ensembles, and performing contemporary music. Aside from bass clarinet, students also learn about entrepreneurship and collaboration with other musicians so that they can create their own careers upon graduation. The master's degree is a two year course involving performance of a variety of music and in a variety of ensembles. Table 4 shows the auditions requirements for students pursuing a master's degree in bass clarinet, and Table 5 shows the course outline which concludes with a final research project.

Table 4. Amsterdam Conservatory: Admissions for Master of Music in Bass Clarinet<sup>196</sup>

<b>Admissions for Master of Music in Bass Clarinet, Amsterdam Conservatory</b>	
Conservatorium von Amsterdam Students	<ol style="list-style-type: none"> <li>1. Upon taking the final examination for the bachelor's degree programme, Conservatorium von Amsterdam candidates must have received the distinction eligible for acceptance to the master's degree programme.</li> <li>2. A plan of study drawn up by the candidate and a follow-up discussion regarding the structure of the plan.</li> </ol>
External Candidates	<ol style="list-style-type: none"> <li>1. The candidate will perform a programme which may not exceed 30 minutes. He/she is required to play at least one piece from memory.</li> <li>2. The candidate must submit a list of repertoire with a proposed programme for the entrance examination to the Conservatorium von Amsterdam study secretariat before March 1st. This programme will include a variety of musical styles. The admissions committee will evaluate the proposed programme and make any necessary changes. General requirements may be obtained from the representative of the section.</li> <li>3. Required works for the entrance examination include: Tristan Keuris - Concertino (plus string quartet), Othmar Schoeck - Sonata, P. Hindemith - (Bassoon) Sonata.</li> <li>4. Clarinetists having played little of the contemporary repertoire for bass clarinet during their studies will play: Debussy - Cello Sonata, Bach - Cello Suites.</li> <li>5. The repertoire performed will support the motivation outlined in the plan of study. The candidate's personal approach will be evidenced by a follow-up discussion regarding the structure of the plan.</li> </ol>

<sup>196</sup> "Classical Music Study Guide Master's Degree Programme 2014-2015," accessed January 17, 2015, <http://www.ahk.nl/en/conservatorium/study-programmes/master/master-classical-music/woodwinds/bass-clarinet/>.

Table 5. Amsterdam Conservatory Course Description: Master's Degree in Bass Clarinet

<b>Conservatorium of Amsterdam: Master of Music in Bass Clarinet</b>	
Learning Objective:	After the two-year course, students will have been able to develop their talents in line with the plan of study. They will then be ready to enter the professional music world at the highest level.
Principal study:	<p>Principal subject Solo repertoire. Principal private lessons by appointment.</p> <p>Final project The student will adopt a more specialized approach to the repertoire of his/her principal study and will undertake research, on which he/she will report. To be determined by the student himself/herself.</p> <p>Additional instruction in the principal study</p> <ul style="list-style-type: none"> <li>- coached ensemble playing</li> <li>- course on orchestral playing/training for auditions</li> <li>- chamber-music projects</li> <li>- orchestra projects</li> </ul> <p>Student activities Playing, performing, participating in ensembles and projects.</p> <p>Methods of instruction Individual lessons, group lessons.</p> <p>Principal subject 'free space' selection Serving as a deputy player, e.g. with the Asko Ensemble, chamber-music ensembles and orchestras</p>
Other subjects:	Students may choose from a number of master level subjects and additional 'free space' electives. Information on research is provided separately.
Evaluation:	<p>Assessment Following the First Academic Year</p> <ol style="list-style-type: none"> <li>1. A performance on the basis of which the student's progress in the area of the principal study will be assessed. The performance must demonstrate the student's positive development in respect of his/her: <ul style="list-style-type: none"> <li>- musical personality</li> <li>- instrumental skills</li> </ul> </li> <li>2. The candidate's own views on and initiative with respect to the course will also be considered in the assessment.</li> <li>3. The candidate will give an end-of-year recital and must perform at least one piece from memory. Examples of repertoire: W. Siegel - Jackdaw (+ tape), G. Janssen - Sprezzatura (solo), J.R. v. Roosendaal - Kaida (fl, b cl, pf), T. Bruynèl - Looking ears (b cl, pf, tape), J. Kunst - Solo Identity I (solo), Y. Yuasa - Clarinet Identity (version for bass clarinet)</li> <li>4. The performance will not exceed 50 minutes.</li> </ol>
Final Examination	<ol style="list-style-type: none"> <li>1. The candidate will give a final recital; he/she will present a cohesive programme based on a personal vision. The programme will include an accompanying lecture or written programme notes, or a master level thesis.</li> <li>2. The recital will be made up of the following repertoire or repertoire of the same level: I. Yun - Monolog, F. Donatoni - Het (fl, b cl, pf), T. Loevendie - Duo for One Bass Clarinet solo + orchestra, T. Loevendie - Incantations, I. Xenakis - Echange</li> <li>3. Together, the concert and the lecture will not exceed 90 minutes. The candidate must submit his/her programme no later than 1 March to the study secretariat using the forms provided for that purpose.</li> </ol> <p>The final examination will be evaluated by a committee comprised of a representative of the Board of Directors, principal study teachers and an external committee member. Research to be evaluated separately.</p>
Criteria for completion:	<ol style="list-style-type: none"> <li>1. Credits to be earned in connection with the final examination: credits in respect of the principal subject. Research/lecture credits will be earned separately.</li> <li>2. Additional subject credits, as part of the principal study, to be earned.</li> <li>3. Master level subjects and 'free space' credits to be earned.</li> </ol> <p>Students will be admitted to the final examination only after the credits referred to above in the second and third points of the list of criteria have been earned.</p>

*Conservatorio di Musica “giuseppe Verdi” di Milano*, master’s degree in bass clarinet

The music conservatory of Milan is an example of a curriculum that offers specialization in bass clarinet at the master’s level. Clarinet courses are offered at Level I, Level II, and Master’s. Level I is an undergraduate three-year course and does not offer specialization in bass clarinet or auxiliary clarinets. Level II is a two-year postgraduate degree, which offers two options for clarinetists; students can specialize in clarinet only, or they can choose to study clarinet with specialization of an auxiliary clarinet (e-flat clarinet, basset horn, or bass clarinet). Students studying auxiliary clarinets study clarinet during the first year and add a secondary instrument in year two, which is taught in conjunction with clarinet. Master’s degrees in clarinet and bass clarinet are also offered as a two-year program designed to prepare students for the competitive job market, both in orchestral studies and in contemporary techniques. The Master’s in bass clarinet is taught by Stefano Cardo, solo bass clarinet of the *Teatro alla Scala* and *Filarmonica della Scala Orchestra* and, Alberto Serrapiglio teacher of the *Conservatorio “G. Verdi” of Milano*. The Master’s in bass clarinet does not include the study of clarinet.

The following is a breakdown of the two-year course for a Master’s in bass clarinet at the Conservatory of Milan, and includes audition procedures, Part I and Part II. Part I focuses on traditional performance while Part II is based on contemporary music. The course outline for 2014/2015 is redesigned from the 2013/2014 outline. Both course outlines are posted by Stefano Cardo at [stefanocardo.org](http://stefanocardo.org), and both are shown in Tables 6 and 7.

Table 6. Conservatory of Milan: Master's Degree in Bass Clarinet 2013/2014

<b>Master of Bass Clarinet, Conservatory of Milan 2013/2014</b>	
Program for admission:	<p>1. a suite for cello solo by J. Sebastian Bach</p> <p>2. a work of your choice for solo bass clarinet and/or with piano from the most renowned repertoire for bass clarinet.</p>
Course of Study: Bass Clarinet Ia – prof. Stefano Cardo	<p>Deepening of the classic techniques for bass clarinet:</p> <p>Four of the Six Suite for Solo Cello by J.S. Bach</p> <p>S. Neukomm: Make Haste, O God for bass clarinet, piano, soprano and string quartet</p> <p>W. Gabriel: Ballade Op. 23 for bass clarinet and piano</p> <p>D. Brosse: Elegy for bass clarinet and piano</p> <p>L. Sluka: Notturmo for bass clarinet and piano</p> <p>L. Sluka: Sonata for bass clarinet and piano</p> <p>H. Genzmer: Sonata for bass clarinet solo</p> <p>M. Kibbe: Sonata Op. 40 for bass clarinet and piano</p> <p>The opera and symphonic repertoire:</p> <p>R. Wagner - Tristan und Isolde, Das Rheingold, Die Walküre, Siegfried, Götterdämmerung, Tannhauser</p> <p>G. Verdi - Aida, Ernani, Simon Boccanegra</p> <p>D. Shostakovich - 6<sup>a</sup>, 7<sup>a</sup>, 8<sup>a</sup> symphony, Violin Concerto</p> <p>R. Strauss - Frau ohne Schatten, Don Quixote, Till Eulenspiegels Lustige Streiche</p>
Bass Clarinet IIa, IIb – prof. Alberto Serrapiglio	<p>P. Jean-Jean - 16 studi moderni</p> <p>A. Uhl – 48 Studi per clarinetto</p> <p>The new instrumental techniques for bass clarinet</p> <p>The solo performance, including improvisation, with the use of new technologies (iPad, loop station, etc. ...) and / or streaming online</p> <p>The bass clarinet repertoire with electronics:</p> <p>W. Siegel: Jackdaw</p> <p>J. Ter Veldhuis: Grab It</p> <p>A. Serrapiglio: Suite</p> <p>M. Smetanin: Ladder of Escape</p> <p>The bass clarinet contemporary repertoire:</p> <p>F. Donatoni: Soft</p> <p>L. Berio: Sequenza IXc</p> <p>S. Bussotti: Brutto, Ignudo</p> <p>C. Boccadoro: Walk</p> <p>G. Scelsi: Ixor</p> <p>A. Haba: Suite Op. 96</p> <p>D. Loeb: 5 Sonatas</p> <p>I. Loudova: Aulos</p> <p>G. Arrigo: Par un Jour d'automne...</p> <p>E. Dophy: God Bless The Child</p> <p>V. Globokar: Voix Instrumentalisée</p>

Several elements of the Milan course are taken into account for the construction of the suggested course of study for bass clarinet and clarinet at the undergraduate level. Most important, the Milan course offers an equal foundation in traditional and contemporary studies, beginning with traditional studies before incorporating contemporary works and extended techniques. This same concept is applied to the suggested curriculum in Chapter 4.

Table 7. Conservatory of Milan: Master's Degree in Bass Clarinet 2014/2015

<b>Master of Bass Clarinet, Conservatory of Milan, 2014/2015</b>	
Program for admission:	<ol style="list-style-type: none"> <li>1. H. Genzmer: "Sonata" for bass clarinet only first time</li> <li>2. F. Donatoni: "Soft" for bass clarinet only or C. Boccardo: "Walk" for bass clarinet only or L. Berio: "Sequence IXc" for bass clarinet only</li> </ol>
Course of Study:	<p style="text-align: center;">Bass clarinet Ia, Ic - prof. Stefano Cardo</p> <ol style="list-style-type: none"> <li>1. Two suites of Bach (the last two that remain from the path of the first level in 2 years)</li> <li>2. The following compositions for bass clarinet and piano: O. Schoek: Sonatas ; L. Sluka: DSCH ; HJ Zander: Capriccio</li> <li>3. Concerts for bass clarinet and orchestra of the first half of the twentieth century</li> </ol>
	<p style="text-align: center;">Bass clarinet IIa, IIc - prof. Alberto Serrapiglio</p> <ol style="list-style-type: none"> <li>1. D. Lang: Press Release for bass clarinet only</li> <li>2. S. Gubaidulina: Dots, Lines and Zigzag for bass clarinet and piano</li> <li>3. The concerts for bass clarinet and orchestra or chamber orchestra of the second half of the twentieth century and the twenty-first century;</li> <li>4. The composition for bass clarinet and chamber orchestra commissioned for the final examination of the Master's Degree of bass clarinet</li> </ol>
Program of Examination [recital program]	<p style="text-align: center;">BASS CLARINET Ia - prof. Stefano Cardo</p> <ol style="list-style-type: none"> <li>1. One of the compositions for bass clarinet and piano studied during the Master's Degree</li> <li>2. Concerto for bass clarinet and orchestra of the first half of the twentieth century</li> </ol> <p style="text-align: center;">BASS CLARINET IIa - prof. Stefano Cardo</p> <ol style="list-style-type: none"> <li>1. D. Lang: Press Release for bass clarinet only</li> <li>2. S. Gubaidolina: "Dots, Lines and Zigzag" for bass clarinet and piano</li> </ol>
Final Exam Schedule	<p style="text-align: center;">BASS CLARINET Ic, IIc</p> <ul style="list-style-type: none"> <li>- A Bach Suites for solo cello, in transcription for clarinet, among those studied during the trial</li> <li>- One of the compositions for bass clarinet and chamber orchestra among those studied during this Master;</li> <li>- The composition for bass clarinet and chamber orchestra commissioned for the final exam of this Master.</li> </ul>

The course of study at the Conservatory of Milan is a prime example of a curriculum built around standard bass clarinet literature and these works are included in the suggested undergraduate course found in Chapter 4. The most important differences between the Milan course and the following suggested course is that the suggested course involves the study of clarinet and bass clarinet simultaneously from Level 1 through Level 5 at the undergraduate level, and it is designed to include clarinet students who have no previous experience playing bass clarinet.

*Boston Conservatory*

The Boston Conservatory now offers a graduate degree in “Woodwinds with Auxiliary Instrument Specialization.”<sup>197</sup> Specializations include flute and piccolo, oboe and English horn, clarinet and bass clarinet, and bassoon and contrabassoon.<sup>198</sup> Audition requirements for the clarinet with specialization in bass clarinet are shown in Table 8, and posted on the conservatory website.

Table 8. Boston Conservatory: Audition Requirements for Clarinet with a Specialization in Bass Clarinet

Students interested in applying for graduate level programs in woodwinds now have the option of formally declaring an auxiliary instrument specialization. The core curriculum for these specializations is nearly identical in structure to other graduate level programs in woodwinds. Accepted students who declare auxiliary instrument specializations will note the specialized work in the applied area (private lessons, juries, and recitals), large ensembles (with casting priority on the specialized instrument), and the possibility of Chamber Music assignments.	
Clarinet	- Two contrasting movements of your choice from the standard solo repertoire (e.g. Mozart Concerto, Weber Concerti, Nielsen Concerto)
Bass Clarinet	- One movement of a J.S. Bach Cello Suite (original or transposed keys) - One contemporary solo piece of your choice (e.g. Elliott Carter- Steep Steps, Loevendie - Duo, Isang Yun - Monologue) - Your choice of TWO of the following orchestral excerpts <ul style="list-style-type: none"><li>o Ravel - La Valse</li><li>o Stravinsky – The Rite of Spring</li><li>o Grofé - Grand Canyon Suite</li><li>o Shostakovich - Violin Concerto</li><li>o Ravel - Daphnis &amp; Chloé Suite No.2</li></ul>

Although the entire course of study is not described, the audition requirements suggest that there is more emphasis on orchestral excerpts than the previous courses of study. The excerpts and solo repertoire will be included in the course of study for clarinet and bass clarinet at the graduate level along with study in orchestral excerpts.

<sup>197</sup> “The Boston Conservatory/Graduate Music Audition Requirements,” accessed January 17, 2015, <https://www.bostonconservatory.edu/graduate-music-audition-requirements#wwaux>.

<sup>198</sup> Ibid.

## *The Paris Conservatory*

The Paris Conservatory offers two years of study on the bass clarinet at the master's level. Jean Noël Crocq was the first professor of bass clarinet at the Paris Conservatory (1990 – 2013) and bass clarinetist at the *Opera de Paris* (1974 – 2008). In the article “The Bass Clarinet Class of the Paris Conservatory, 1990 – 2013” he discusses the goals of the course and outlines the literature most often taught and performed.<sup>199</sup>

The goals cover all areas of bass clarinet performance:

After a period of progressive work, the content of teaching must meet the technical requirements of a modern symphony orchestra as well as the intensive use of the bass clarinet in contemporary music.

Areas of focus include orchestral excerpts, study repertoire, pieces with piano, solo bass clarinet pieces, duets and trios with various instruments, and electroacoustical pieces.

Paris Conservatory: Course of Study for Bass Clarinet<sup>200</sup>

Orchestral Excerpts:

Berg, Bernstein, Boulez, Charpentier (Gustave), Shostakovich, Dukas, Dusapin (*Perela*, opera), Franck (Cesar), Gershwin, Janáček, Khachaturian, Ligeti, Mahler, Messiaen (piece: *Chronochromie*), Mussorgsky-Ravel, Pintscher (piece: *L'Espace dernier*), Prokofiev, Ravel, Schoenberg, Strauss (Richard), Stravinsky, Tchaikovsky, Verdi, Wagner

Study Repertory:

Stravinsky: First of *Three Pieces*  
Lancelot: first six of 26 *Études élémentaires*  
Bach: Cello Suites  
Delécluse: first seven of 20 *Études faciles d'après Samie*  
Blancou: no. 21 of 40 *Études*

---

<sup>199</sup> Jean Noël Crocq, “The Bass Clarinet Class of the Paris Conservatory, 1990 – 2005,” *The Clarinet* 41, no. 4 (September 2014): 52.

<sup>200</sup> *Ibid.*, 56.

Pieces with Piano:

Barboteu: *Rencontre*  
Brahms: *Cello Sonata*, Op. 38  
José Carlos Campos: *Duo Concertante*  
Gallois Montbrun: *Concertstück* (B-flat)  
Gaubert: *Fantaisie* (B-flat)  
Jean-Claude Henry: *Voies intérieures* for cello, first and third mvts.  
Jolas: *Petite musique de chevet*  
Mendelssohn: *Lied Ohne Worte*, Op. 109 No. 4, for cello  
Mozart: *Airs de Sarastro*  
Martin: *Bassoon Concerto*  
Othmar Nussio: *Variations on a theme of Pergolese*  
Paganini: *Variations on Moses Theme of Moïse*  
Thierry Pécou: *Salsa d'Elissa*; Rabaud: *Solo de concours*  
Karel Reiner: *Bass Clarinet Concerto*  
Reissiger: *Duo Brillant*  
Revel: *Fantaisie*  
Rossini: *Introduction, Theme & Variations*  
Saint-Saëns: *Le Cygne*, Cello Concerto  
Schoeck: *Sonata*, Op. 41  
Sciortino: *As-If*  
Semler-Collery: *Légende et Divertissement*  
Spohr: *Adagio of Concerto 2*  
Alain Weber: *Cheminements*

Solo Bass Clarinet:

Aperghis: *Simulacre IV*  
Claudio Ambrosini: *Hermaphrodite*  
Busch: *Suite*, Op. 37a  
Cage: *Sonata*  
Carter: *Steep Steps*  
Donatoni: *Soft*  
Dusapin: *Itou*  
Genzmer: *Sonata*  
Jarrell: *Assonances III*  
Sergio Menozzi: *Etude Swing*  
Michèle Reverdy: *It Didn't Crash!*  
Étienne Rolin: *Arcades, Mémoire pour Dolphy*  
Sutermeister: *Capriccio* (originally for clarinet in A)  
Yun: *Monolog*

Duets and Trios with Various Instruments:

Graziane Finzi: *9 min 30*  
Fedele: *Modus*

Pierre Jansen: *Quelques fragments enchainés*  
Louvier: *Diurne*

Electroacoustical Pieces:

Luis Naon: *Capriccio no. 3 et 4*  
Enrique Raxach: *Chimaera* w/tape  
Ton de Leeuw: *Mountains* w/tape  
Ton de Leeuw: *Concerto* with orchestra  
Vincent Guyot: *Pour clarinette basse et orchestra*

Methods:

Henri Bok: *New Techniques for the Bass Clarinet*  
Jean-Marc Volta: *La clarinette basse: Méthode*

Each of the programs outlined above offer pros and cons for bass clarinet students. The Amsterdam course offers a bachelor's degree, but it does not include simultaneous instruction of the clarinet. The Paris Conservatory, the Conservatory of Milan and the Boston Conservatory offer master's degrees with specialization in bass clarinet, but none offer studies at the undergraduate level. The admission repertoire at the Conservatory of Milan and Boston Conservatory is demanding enough that students need previous study on the instrument to be admitted. If specialized degrees at the graduate level exist, then preparation for these programs should take place at the undergraduate level. Also, although the courses overlap in some ways, they are each designed to attain different goals, either based more heavily in contemporary/collaborative music, or in more traditional/orchestral music. The suggested course of study in Chapter 4 aims to provide students with a well-rounded curriculum so that they can succeed in any area of performance or continued study, and the bass clarinet courses presented above provide models for literature and goals to be incorporated when possible.

### *Programs that Offer Multiple Woodwind Degrees*

Performance degrees in multiple woodwinds usually include private study of three to five woodwinds, and are most often geared toward students who want to perform in musical theater. There are several elements of the multiple woodwinds degree that translate to the study of clarinet and bass clarinet: (1) students must learn to switch between two or more instruments very quickly, which includes changes in embouchure and fingerings, (2) transposition and clef reading may be necessary, especially for students doubling on bassoon, (3) students present a recital on all instruments at the end of the course. Although there are several universities that offer multiple woodwinds degrees, the programs discussed in this document are the University of North Texas and Indiana University.

The University of North Texas offers a multiple woodwinds degree at the undergraduate level and is an example of how multiple instruments can be incorporated into the curriculum. Students study a primary instrument while learning four additional auxiliary instruments. The first auxiliary instrument is introduced in the first semester, and a year is spent studying each instrument before beginning a new instrument.<sup>201</sup>

Indiana University offers a degree in which students can choose to specialize in five or three instruments. Students study their primary instrument every year while simultaneously learning secondary instruments. Degree plans for five instruments allocate two semesters to each auxiliary instrument with the exception of one, which is allocated to only one semester of study. Degree plans for three woodwind instruments

---

<sup>201</sup> “BM with a Major in Performance (Specialization: Orchestral Instruments - Multiple Woodwinds),” University of North Texas sample degree plans, accessed January 16, 2015, <http://www.unt.edu/catalogs/97-98/bmperforchestrawoods.html>.

includes the primary instrument, allocates four semesters to one auxiliary instrument and three semesters to another.<sup>202</sup>

### *Traditional Programs*

Traditional programs are those that focus on B-flat soprano clarinet and have built a curriculum from standard clarinet repertoire. The suggested curriculum has been modeled after traditional programs and, in particular, well-known pedagogues such as Michele Gingras, Distinguished Professor at Miami University and author of *Clarinet Secrets—52 Performance Strategies for the Advanced Clarinetist*, Howard Klug, Professor of Clarinet at Indiana University and author of *The Clarinet Doctor*, and Caroline Hartig, Professor of Clarinet at Ohio State University.<sup>203</sup> Each of these pedagogues has an established core curriculum they use for teaching, and these sources serve as models for the suggested course of study in this document.

---

<sup>202</sup> “Bachelor of Music, Woodwind Instruments (Multiple),” Indiana University degree requirements worksheet, accessed January 16, 2015, <http://music.indiana.edu/degrees/undergraduate/requirements/BMMultWW.2014.pdf>.

<sup>203</sup> Michele Gingras, *Clarinet Secrets: 52 Performance Strategies for the Advanced Clarinetist* (Lanham: The Scarecrow Press Inc., 2004); Howard Klug, *The Clarinet Doctor* (Bloomington: Woodwindiana, 2009); Caroline Hartig, “OSU Spring 2013 Studio Events,” accessed January 2, 2015, <http://www.carolinehartig.com/clientuploads/THE%20OHIO%20STATE%20UNIVERSITY%20SYLLABUS%20SPRING%202013.pdf>.

## **Chapter 3**

### **Bass Clarinet Literature Methods and Studies**

The criteria for classification of literature is outlined below and followed by a selected, annotated bibliography of methods and works to be included in the final course outline. Each annotation describes the work, how it can be incorporated into the curriculum, classifies the work according to the level of study that is most applicable.

#### **Criteria for Literature Classification**

Rather than assigning literature and studies to Freshman, Sophomore, Junior, and Senior years, the criteria and goals are described according to various levels. Every student has a different background in musical study. Some students will enter the university with prior bass clarinet experience, and be able to start at Level 2 or 3, while other students may not have had any experience with bass clarinet, and thus need to start at Level 1. Ideally, Level 1 begins freshman year. Five levels are included, the fifth being ideal for graduate students and professionals.

#### **Level 1**

Level 1 is designed for the first year undergraduate clarinetist playing bass clarinet for the first time. Most exercises are geared toward becoming familiar with the instrument and learning the bass clarinet's tendencies with regard to voicing, tuning, air-support, etc. Extended keys and altissimo range is not yet included. The goal is to

produce a quality sound and develop technical facility in relation to the techniques already established on clarinet.

#### Level 2

In Level 2, emphasis is placed on becoming familiar with and developing technical facility in the extended low range of the bass clarinet. Secondary goals are to introduce the altissimo range and harmonics. It is highly recommended that universities own an extended range bass clarinet, since it is now becoming standard for bass clarinetists to own and play extended range instruments.

#### Level 3

In Level 3 emphasis is placed on proficiency of reading bass clef in all notations and maintaining technical proficiency in the extended low range. Secondary goals include development of technical facility in altissimo register, introduction to reading bass clarinet in A and introduction to extended techniques. Continued development of proficiency in the extended low range is critical.

#### Level 4

In Level 4 emphasis is placed on the altissimo range of the instrument and extended techniques. Students should continue the study of French, German, and Mixed notation. At this point, students should establish a solid foundation with regard to technique and tone. Multi-phonics and the extremely-high range of the instrument should become a regular part of the student's studies.

## Level 5

Level 5 is designed for advanced undergraduates and first year graduate students. It is at this point that students should be making more decisions on their own with less guidance from the teacher; therefore, Level 5 offers a more general guide with regard to methods and warm-ups so that students have the opportunity to determine which studies and warm-ups work best for them. There should be a solid foundation in place with regard to tone production, technical facility, and proficiency of the extended low, altissimo, and extremely-high ranges. Students should also demonstrate proficiency at reading French, German, and Mixed notation. Transposing for bass clarinet in A should become easier at this point. Emphasis at Level 5 is placed on extended techniques and expanding the student's knowledge of bass clarinet solo literature.

### Methods and Studies

Warm-ups for the bass clarinet player should be incorporated as a daily exercise done prior to extensive playing. The main focus of warm-ups is to gain control and mastery of air, tone, dynamics, and intonation before moving on to more technically demanding exercises and works. Methods and studies are also incorporated into daily practice and should begin at a level in which the student can master the work in one to two weeks. The portion below describes the bass clarinet studies and warm-ups, explains how they can be incorporated into a course of study, and why they are beneficial to students first learning to play bass clarinet.

*Warm-ups and Introductory Methods*

Volta, Jean-Marc. *The Bass Clarinet*. Paris: International Music Diffusion, 1996.

*The Bass Clarinet* by Jean-Marc Volta is an incredibly valuable resource that can be used by teachers and students who have little to no experience with bass clarinet. *The Bass Clarinet* can be incorporated at every level of study and is applicable to every area of performance, from orchestral excerpts to modern/extended techniques. It can be used as a foundation for teaching bass clarinet by incorporating the studies provided as a regular part of warm-up. Segments from this book will be included in the suggested course outline according to what is most appropriate for student development.

The book includes orchestral and solo excerpts throughout, usually at the beginning of each exercise, in order to demonstrate practical application of the study. Explanations about breathing, relaxation, embouchure, articulation, finger control, voicing, and enharmonics are clear, easy to understand, and applicable to all musical situations. One section of the book is devoted to these fundamental elements, which are continually reinforced throughout. An excellent introduction and progressive study of the low extended notes is included, and detailed fingering charts are provided throughout. Particularly unique is the approach to teaching altissimo fingerings, in which the bass clarinetist learns traditional fingerings first and incorporates open fingerings later. Once students have mastered both types of fingerings, they then play etudes in the altissimo range twice; the first time using traditional fingerings and a second time using open/short fingerings. Transposition is also encouraged throughout.

Voxman, Himie. *Introducing the Alto or Bass Clarinet: A transfer method for intermediate instruction*. Chicago: Rubank, 1952.

Since this is really an intermediate study designed for young students, it should only be used as an introduction for college studies during the first few weeks of playing bass clarinet. Although the first lessons are quite elementary for college students, the book is a great introduction for those who have never played bass clarinet. The etudes toward the middle and back of the book are not terribly difficult and are useful for becoming acquainted with the instrument. The first section of the book works mostly in the low register, which is least resistant, so students can focus on becoming familiar with the keys and feel of the bass clarinet. A second section includes exercises for register changes, addressing pressure and voicing differences between bass and soprano clarinet. Chromatic studies are short, providing an easy introduction to learning the location of keys on bass clarinet as compared to soprano. Since the bass clarinet is not completely different from the clarinet, I recommend only using this study for the first few weeks and then moving on.

## *Scale Studies*

Arnold, Martin. *Bass Clarinet Scale Book*. Toronto: Aztec Press, 2003.

To meet the goals of Level 2, students should transition from the Rhoads scale studies to the Arnold scale studies in order to become acquainted with the extended keys and reading bass clef. In the introduction, Arnold addresses issues such as reading bass clef, transitioning from bass to treble clef when reading French or German notation, transposing parts for bass clarinet in A, and learning to use the extended keys of low C bass clarinets. The book includes all major/minor scales alternatively and technical studies in all keys written first in treble clef and again in bass clef. Martin also points out the problem of low key placement and encourages practicing scales using as many alternate fingerings as possible each time.

Martin Arnold is the bass clarinetist for the Mexico-City Philharmonic, and completed his master's degree at Indiana University under the instruction of Lawrie Bloom.

Rhoads, William E. *Baermann for the Alto and Bass Clarinet, from Division Three Celebrated Method for Clarinet by Carl Baermann, Op. 63*. San Antonio: Southern Music Company, 1963.

Rhoads' book has been adjusted from Carl Baermann's *Complete Celebrated Method for Clarinet, Op. 63*. In Rhoads' adaptation, the scales extend to altissimo D rather than the altissimo G in Baermann's book. No low extended range is included.

## *Methods, Guides, and Studies*

Berti, Sauro. *Ludwig Milde, Studi da Concerto op. 26: Versione per clarinetto basso*. Cesena: MusiGramma srl, 2011.

Ludwig Milde is a well-known composer for bassoon, and his 50 Concert Studies, Op. 26, have been adapted for the bass clarinet by Sauro Berti. The book is comprised of etudes that are excellent for developing musicianship, musicality, and interpretation, as well as technical facility. Most of the etudes contain both treble and bass clef, making this an ideal study for Level 3 students. A low C instrument is required.

Bona, Pasquale. *Rhythmical Articulation: Parts 2 and 3 from the Complete Method*. Trans. William D. Fitch. New York: Carl Fischer, 1969.

Originally intended to teach vocal "sight-reading, rhythmic accuracy, and articulation," this study has been transcribed for instruments in bass clef. Etudes progressively become more challenging and are composed in all keys. Designed

for students aiming to become proficient at reading bass clef, this book could be introduced at the end of Level 2 with continued use through Level 5.

Gabriel, Wolfgang. *Etudes for the Bass Clarinet: op. 85, Vol. 1 and 2*. Tacoma: Alea Publishing, 2004.

This book, divided into two sections, can be incorporated at all levels. The first portion, composed by Michael Davenport, consists of exercises that include scales in ninths, scales in thirds, scales in fourths, and breath support exercises. The second part of the book is “Etudes Volume 1,” which begins with a series of studies designed to develop breath control and interval leaps. “Etudes Volume 2” becomes progressively more difficult by expanding the range, increasing complexity of rhythms, varying articulations, and changes in time signature. A low C instrument is required.

Pellegrino, Michel. *Petit précis de clarinette basse*. Paris: Editions Henry Lemoine, 2009.

Although this book was only used by one participant of the questionnaire, I believe it is a valuable resource for bass clarinetists. It is laid out similarly to the Volta beginning with information about equipment, followed by preparatory exercises, register exercises, altissimo fingerings, effects for contemporary music, and exercises for embouchure. The fingering guide is quite clear and the section describing effects is precise and to the point. The book is compact and is great to have on hand in any situation. It is recommended for use at all levels.

Rhoads, William E. ed. *18 Selected Studies for Alto and Bass Clarinets*. San Antonio: Southern Music Company, 1963.

———. *21 Foundation Studies for Alto and Bass Clarinet*. San Antonio: Southern Music Company, 1965.

———. *Advanced Studies from the Works of Julius Weissenborn: Adapted for Alto and Bass Clarinets*. San Antonio: Southern Music Company, 1973.

———. *Etudes for Technical Facility for Alto and Bass Clarinet*. San Antonio: Southern Music Company, 1965.

These four books are a compilation of studies adapted by William E. Rhoads for the bass clarinet. They are excellent studies to develop technical facility for bass clarinetist from Level 1 to Level 2 and are similar in style and technical difficulty to one another. Studies from the Weissenborn adaptation are generally shorter and might be best for first semester bass clarinetists. Other works are adapted from Rose, Lazarus, and Ferling, among others. These studies occasionally go down to low E flat and are not composed for instruments with a

low C extension, and they work well in the introductory semester since the exercises do not extend upward beyond thumb C.

Rubio, Pedro. *101 Studies for Bass Clarinet. 25 Progressive Studies, first register until low C*. Madrid: Música Didáctica S.L., 2004.

This book builds facility for the extended range of the bass clarinet and should be included as a core part of the curriculum. Should clarinetists not have access to a low C instrument, an alternate part is included. The primary focus of the studies in this book is the extended low range, and there are no exercises that include the altissimo range. This allows students at Level 2 to become proficient in the low range. This book can and should overlap studies in Level 3.

Rubio, Pedro. *101 Studies for Bass Clarinet. 30 Progressive Studies for German Notation System*. Madrid: Música Didáctica S.L., 2006.

After becoming proficient with *25 Progressive Studies for the Bass Clarinet*, the student can then move to Rubio's second book of etudes *30 Progressive Studies for the Bass Clarinet*; however, the emphasis in this book is on reading bass clef. The first study introduces French, German, and Mixed notation (used by Stravinsky), lining them up together so the student can see how each type of notation should be read. Studies 2 through 11 are composed in German notation. The book is an excellent study for reading bass clef and pairs well with Martin Arnold's *Scale Book for Bass Clarinet*. Appropriate for Level 3 through Level 5.

#### Orchestral Excerpts

Drapkin, Michael. *Symphonic Repertoire for the Bass Clarinet*. 3 vols. Glenmore: Roncorp Publications, 1979-2004.

Michael Drapkin has compiled three volumes of orchestral excerpts for the bass clarinet. The works chosen are those found in standard orchestral literature, those which include significant bass clarinet solos, and works most often found on audition lists. Parts are included in the original key and clef so that the bass clarinetist can practice transitioning between clefs and transposing bass clarinet parts in A or C. Drapkin includes information about clef reading and practicing in the forward of each volume, and footnotes are included for excerpts with special rules for notation. A fourth volume will be published soon, and the final list of excerpts for this volume can be found on Drapkin's website [www.bassclarinet.net](http://www.bassclarinet.net).<sup>204</sup>

The study of orchestral excerpts can begin at any point. Orchestral excerpts are introduced at Level 2 in the suggested curriculum found in Chapter 4

---

<sup>204</sup> Michael Drapkin, "Volume Four," accessed February 3, 2015, <http://www.bassclarinet.net/volumefour/>.

so that students can build fundamentals (air support, tone production, and technical proficiency) before attempting demanding orchestral literature.

Giampieri, Alamiro. *Passi Difficili e "A solo" per clarinetto e clarinetto basso*. 2 vols. Milan: G. Ricordi, 1936-41.

These books are not solely dedicated to the bass clarinet. In fact, in volume 1 the majority of the excerpts are for B-flat and A clarinets, although more excerpts for the bass clarinet are found in volume 2. Unique to these books is that they contain excerpts not found elsewhere and include passages from important operas. For example, the solo in Meyerbeer's *Les Huguenots* is found in volume 1 while volume 2 includes operatic passages for the bass clarinet by Verdi and Wagner, as well as orchestral excerpts by Franck and Liszt. These books would also provide an opportunity to practice switching between instruments. As with the Drapkin books, it is recommended to start working from these books at Level 2.

Wagner, Richard. *Orchestral Excerpts from Operas and Concert Works for Clarinet and Bass Clarinet*. Edited by Gudrun Hinze. New York: International Music Company, 1970.

This collection of excerpts is completely devoted to the orchestral works by Wagner. A majority of the excerpts are for soprano clarinet in A and B flat, but important solo lines for bass clarinet are included as well. Although this book is not completely dedicated to bass clarinet, it has important solo lines and it is excellent to practice switching between bass and soprano. This book is recommended at Level 2.

### Concerti

Callaway, Ann. *Concerto for Bass Clarinet and Chamber Orchestra*. Ann Callaway Manuscript, 1987.

This is a very rhythmic and challenging piece that requires a great deal of technical control from the bass clarinetist. It does not require a low C bass clarinet, extending only to low E-flat; however, it does move into the altissimo range. No extended techniques are required, therefore this is a Level 4 piece or potentially an advanced Level 3. It is comprised of three movements: "Moonrise Soliloquy," "Meteor Showers," and "Journey on a Summer Night." It does not seem that a piano reduction is currently available.

Erdmann, Dietrich. *Konzert für Bass-Klarinette und Orchester*. Berlin: Ries & Erler, 1993.

This piece was not originally on the list in the questionnaire, but was suggested by several of the participants. It is a challenging Level 3 concerto that does not call for extended low notes, although one must play in the altissimo range fairly often. The solo is in mixed notation and transitions from treble to bass clef. Although it is technically difficult, the piece requires no extended techniques. A recording from 1994 by Renate Rusche with *Berliner Symphoniker* is available.

Goodman, Todd. *Concerto for Bass Clarinet and Orchestra*. Midland: Wrong Note Media Inc., 2008.

Commissioned by Bruce Lauffer and the Beaver Valley Philharmonic, and premiered by Calvin Falwell, Todd Goodman's *Concerto for Bass Clarinet and Orchestra* is a modern work based on traditional tonality. With only two movements, this piece portrays the relationship of parent and child. "Promenade Comique," the first movement, represents an argument between the two. The parent, represented by the orchestra, plays a stern, steady march, and the bass clarinet as the child plays a fun, silly melody. The movement escalates as the parent becomes frustrated with the child. For a moment the two switch roles and then return to their original banter. The second movement, "A Berceuse et Rêve," is a lullaby and dance. Now the bass clarinet is the parent singing a lullaby to the orchestra, which is now the child. The child falls asleep and dreams of dancing, at which point the bass clarinet and orchestra perform a lively *samba*.

This is a light-hearted and entertaining piece. Although fun, the work is still demanding, but does not require extended techniques. This is an excellent Level 3 piece for which a piano reduction is available.

Heucke, Stefan. *Concerto for Bass Clarinet and Orchestra, Op. 33*. Mainz: Schott Musik International, 2011.

Stefan Heucke's concerto is quite challenging, although not as rhythmically complicated as his sonata. The concerto requires extended techniques and proficiency in the extremely-high range of the bass clarinet. The piece consists of three movements and is ideal for students at Level 5. The part is available for German system bass clarinets as well.

Hyla, Lee. *Concerto for Bass Clarinet and Chamber Orchestra*. New York: Pembroke Music Co., 1988.

Lee Hyla's compositional style is said to be an eclectic mix of elements similar to Wolpe and Carter, mixed with jazz and punk rock. The *Concerto for Bass Clarinet and Chamber Orchestra* is no exception. The orchestral accompaniment creates a thin texture, allowing the bass clarinet solo to be easily

heard. There are vivid instructions throughout the score, which indicate that the bass clarinetist should play with attitude and gusto. Technical passages are marked “brutal and driving,” “wailing,” and during lyrical passages there is still a tinge of aggression with words like “urgent, tender, disturbed.” Hyla also incorporates “an old American country song [called] ‘Longest Train I Ever Saw’.” Extended techniques are necessary, as well as a strong foundation in the extremely-high range. The solo is in German notation and is ideal for students at Level 5.

Martino, Donald. *Triple Concerto*. Newton: Dantaliano, Inc., 1978.

Premiered in 1978 by The Group for Contemporary Music, this piece features soprano, bass, and contrabass clarinet with chamber orchestra. Much of the bass clarinet part is composed in the altissimo and extremely-high range. Strings are used in a very rhythmic, percussive manner, and percussion parts call for a variety of instruments and sounds. The wind section is small, but the woodwinds are expected to perform on multiple instruments: flute doubles on piccolo and alto flute, bassoon on contrabassoon, and oboe on English horn. This is a Level 5 work.

Reiner, Karel. *Concerto per clarinetto basso e orchestra: Tre Composizioni per Concerto*. Schott Music Panton, 1966.

Composed in 1966 for Josef Horák, this piece has elements of atonality while still remaining true to the traditional form of a concerto. A transcription for bass clarinet and piano is available, and the original work for bass clarinet, strings, and percussion is quite rhythmic and militaristic. The piece is technically demanding, incorporates the altissimo range, and occasionally the extremely-high range. It is mostly in treble clef, although there is some bass clef. There are extended techniques such as glissandos and harmonics, and a low C instrument is required. This is an excellent work to introduce extended techniques and develop proficiency in the altissimo range. This is an advanced Level 3 or Level 4 work.

Russell, Jonathon. *Bass Clarinet Concerto*. Jonathon Russell Manuscript, 2014.

A recent composition by Jonathon Russell is his bass clarinet concerto. The opening takes advantage of the extremely-high range and the concerto shows the lyrical qualities and colors of the bass clarinet. The piece is structured after Copland’s *Concerto for clarinet and orchestra*, beginning first with a lyrical section in the extremely-high range, a cadenza and then a technical section. Although not technically challenging, the piece involves a great deal of control in the high register and harmonics throughout. A Level 4 work, this is an excellent choice for an advanced student. The piece is available with piano reduction.

Russell, Jonathon. *Bass Clarinet Double Concerto*. Louisville: Potenza Music Publishing, 2010.

Jonathon Russell is a member of the bass clarinet quartet “Edmund Welles” and the duo “Squonk,” two ensembles that merge contemporary music with the sounds of heavy metal and rock.<sup>205</sup> Inspired by these ensembles, the double concerto grooves with the high energy of a rock band, and the idea behind the piece is “Weber’s clarinet concerto meets heavy metal.”<sup>206</sup> The piece incorporates the entire range of the bass clarinet and requires a great deal of control. This is appropriate for students at Level 4 or advanced Level 3.

#### Works with Piano

Bennet, David. *Deepwood*. New York: Carl Fischer Inc., 1937.

Composed in 1936 *Deepwood* embodies the sounds of early twentieth-century entertainment. This is a Level 1 piece due to its limited range and relatively simple rhythms. This is an excellent work for students to become familiar with the instrument.

Bozza, Eugene. *Ballade for Bass Clarinet and Piano*. San Antonio: Southern Music Company, 1958.

This works well as an introductory piece recommended for study at Level 1. It is more rhythmically challenging than the Bennett and the range is from low E to clarion B flat. A short cadenza is included at the beginning, and there are multiple accidentals throughout. *Ballade* works well as a first performance piece.

Desportes, Yvonne. *Andante & Allegro for B-flat Bass Clarinet and Piano*. San Antonio: Southern Music Company, 1969.

This is one of the most well-known works for bass clarinet and is a standard part of the repertoire. While it qualifies as a Level 1 solo, it is deceptively easy. The range is not wide, but most of the melody lies over the break between the chalumeau and clarion register, which is a challenge for first-year students. Therefore, this is recommended as an advanced Level 1 piece.

---

<sup>205</sup> Jonathon Russell, Composer website, <http://jonrussellmusic.com/works/bass-clarinet-double-concerto-chamber-orchestra-version/> accessed March 14, 2015.

<sup>206</sup> Ibid.

Diethel, Friedrich. *Romanze for Bass Clarinet and Piano*. Ruisbroek: Metropolis Music Publishers, 1999.

This is a Level 1 work that could be used to transition to Level 2, since it expands to altissimo D-flat. It is a short piece that is not rhythmically challenging and since the lowest note is low F, no extended keys are required.

Ebenhöh, Horst. *Bassclarpf für Bassklarinetten und Klavier*. Vienna: Musikverlag Hehewarter, 2010.

This is a lesser performed work, however, it is a challenging, five movement piece that would be appropriate for an advanced bass clarinetist at Level 4 or Level 5. The piece is rhythmically challenging due to metric shifts, and coordination with the pianist is a must. Demands include various styles of articulation, extreme leaps, and although there are no extended low notes beyond E, the altissimo range is not neglected. This piece does not include extended techniques.

Eccles, Henry. *Sonata in G minor*. Transcribed by Norman A. Goldberg. New York: Belwin Inc., 1942.

Originally a violin sonata, this transcription is a very nice piece for students at Level 1. The range is equal to that of the clarinet and does not include altissimo notes. With no new notes, clefs, or fingerings to worry about, it is excellent for students to become familiar with the tendencies of the instrument.

Elton, Owen. *Sonata in Bb for Bass Clarinet and Piano*. Owen Elton, 2010.

A fairly recent composition, the sonata by Owen Elton is a melodic piece that is still demanding for the bass clarinetist. Consisting of three movements, each based on visual artists, the piece meets the criteria to be a Level 3 work. The piece requires a low C instrument, although it does not move upward beyond altissimo D. It is also rhythmically demanding with several meter changes and the regular use of mixed meter. Finally, the piano and bass clarinet are intertwined throughout, and a great deal of camaraderie and trust must exist between the two musicians for this piece to work well.

Gabriel, Wolfgang. *Five Bagatelles for Bass Clarinet and Piano*. Tocoma: Alea Publishing, 2005.

This piece is not as technically challenging as Gabriel's other works for bass clarinet. Rhythmically, it is quite straight forward, and would be good for students at Level 3 or beginning Level 4. Although the piece does not require a low C bass clarinet, it does include several notes in the altissimo and extreme high

range, but these are few. The work is composed entirely in treble clef, so transitioning between instruments is not difficult.

Gabriel, Wolfgang. *Sonate für Bassklarinette und Klavier, Op. 30, über Walisische Volkslieder*. Tocomá: Alea Publishing, 2002.

Based on six Welsh folk songs, Gabriel's Sonata is quite challenging and appropriate for advanced Level 4 students and those at Level 5. Included at the front of the score is an explanation of each folk song as follows: *Cob Malltraeth* (Malltraeth Cob, 1<sup>st</sup>, 4<sup>th</sup> and closing movements), *Cân y Cathreinwr* (The Ox-Driver's Song, 2<sup>nd</sup> movement), *Galarnad Cwch Enlli* (The Bardsey Boat Lament, 3<sup>rd</sup> movement), *Y Cap o Las Fawr* (The Cap of Broad Lace, 4<sup>th</sup> movement), *Y Gaseg Ddu* (The Black Mare, 4<sup>th</sup> movement), and *Si So, Gornig* (See-Saw, Swaddled One, 4<sup>th</sup> movement). The piece does not call for extended techniques, but it does involve the extremely-high range of the instrument, and is quite technically demanding. The work is extensive and would be excellent for featuring the bass clarinet in a recital.

Gabriel, Wolfgang. *Sonatine für Bass Klarinet und Piano, Op. 36*. Tocomá: Alea Publishing, 2003.

The *Sonatine* is a Level 4/Level 5 work that, unlike the *Sonata*, is more rhythmically challenging and it only occasionally reaches the extremely-high range. The end of the last movement includes an expressive bass clarinet cadenza.

Heim, Norman. *Incantations of Mephistopheles, Op. 39*. Medfield: Dorn Publications, 1990.

Composed for Harry Sparnaay, this is very technically challenging work that would do well for students at Level 3 and early Level 4. The piece is composed in both treble and bass clef and is great for students to exercise their skills in switching between the two. It requires a great deal of musicality on the part of the bass clarinetist, including two cadenzas and several cadenza-like passages. A low C bass clarinet is required; however, there are no extremely-high notes and only a few altissimo notes.

Heucke, Stefan. *Sonata für Bass Klarinet (or Violoncello) und Piano op. 23*. Mainz: Schott Musik International, 1999.

Composed in 1995, Heucke's *Sonata für Bass Klarinet und Piano* requires a performer comfortable with extended techniques and the extremely-high range of the instrument. Slap tongue, flutter tongue, and timbre changes are just a few techniques asked of the bass clarinetist. An exceptional accompanist is necessary. This would be appropriate for graduate students or very advanced undergraduates and is suggested for Level 5 students.

Kibbe, Michael. *Sonata, opus 40 for bass clarinet (or bassoon) and piano*. Rev. ed. Delaware Water Gap: Shawnee Press Inc., 2005.

While this piece is ranked Level 2, I believe it could also be incorporated at Level 1 for more advanced beginning bass clarinetists. Sonata, op. 40, is written in a neoclassic style modeled after Hindemith. In fact, Kibbe states that “it was my intention to write some pieces for a few of the instruments he ‘missed,’ such as piccolo, bass clarinet and saxophones.” With repetitive melodies throughout, this sonata is good to ease students unfamiliar with neoclassic and atonal music into twentieth-century works. The range is fairly narrow, only extending down to low E with the highest note being clarion C flat. Longer than the Bennett and Bozza pieces, this work is three movements long and would work well as an early recital piece.

Rarig, John. *Introduction & March for Bass Clarinet & Piano*. Los Angeles: Western International Music, Inc., 1968.

This piece qualifies as a Level 1 work due to the lack of extended low notes and no extended techniques; however, this is not an easy piece, and someone unfamiliar with the instrument might have some difficulty with it. Therefore, I would incorporate it as an advanced Level 1 work for students who are beginning to become familiar with the instrument. The piece does call for altissimo D, D-sharp and E, but not for extensive periods of time. Rarig includes the option of playing altissimo notes in the last passage of the piece (6 bars after letter K).

Schoeck, Othmar. *Sonata, Op. 41 for bass clarinet and piano*. Wiesbaden: Breitkopf & Härtel, 1959.

One of the most common and well known pieces for bass clarinet, Othmar Schoeck’s *Sonata Op. 41* is an excellent Level 2 piece. Composed for Werner Reinhart, the part is written entirely in treble clef, and the range is from a low D to altissimo E. Rhythms and key changes can be a little tricky. This is an excellent piece to feature the bass clarinet on a recital.

Sluka, Luboš, *D-S-C-H for Bass Clarinet and Piano*. Panton: Praha, 1997.

This piece is an excellent Level 4 work. Originally composed for cello, it is rhythmically not demanding; however, the range is wide and involves altissimo and extremely-high notes. The work requires a great deal of finesse in all registers and an extended range instrument is necessary, as the lowest note is the extended C sharp. This work is included as an audition piece for several conservatories that offer degrees in bass clarinet, and it should be studied at the undergraduate level. The piece is about eight and a half minutes long and is comprised of three sections: fast, slow, fast. This would work well combined with larger works on a recital for either clarinet or bass clarinet.

Sluka, Luboš. *Sonata for Bass Clarinet and Piano*. Prague: Artia, 1972.

The sonata for bass clarinet is a transcription of Sluka's 1956 sonata for cello, which won the silver medal at the International Composer's Competition in Moscow, 1957. The piece was transcribed for bass clarinet by Josef Horák, and it has also been transcribed for bassoon by Karel Pivoňka a Jiřík Formáček. The sonata by Sluka is a Level 4 work and it is one of the pieces studied for the master's degree at the Milan Conservatory with Stefano Cardo. There are no extended techniques, but the piece often requires the bass clarinetist to play in the extremely-high range. The piece is composed in treble clef and no extended techniques are required. A low C instrument is not required.

Zander, Heinz Joachim. *Ballad for Bass Clarinet and Piano*. Hamburg: N. Simrock, 1993.

Requiring a great command of the altissimo range and technical fluency throughout, *Ballade* is a work for advanced bass clarinetists at Level 5. It only extends to low E, but the highest note is an octave above altissimo C, (C4). There are also sections in which the piano takes over the melody and the bass clarinet remains in the throat tones for several measures. Although the bass clarinet does not have the melody, the pitch and timbre are still quite important and throat tone notes are especially challenging. Aside from a few passages, the bass clarinet is usually leaping very quickly from high to low notes across the full range of the instrument requiring a great deal of control and technical proficiency.

#### Solo Bass Clarinet

Bach, Johann Sebastian. *Suite for Cello Solo, BWV 1007-1012*. Edited by Hugo Becker. New York: C.F. Peters, 1946.

Although these are not composed specifically for bass clarinet, the Bach cello suites are a great resource for bass clarinetists wanting to become proficient at reading bass clef. The repetitive nature allows students to become comfortable with bass clef, the extended range of the instrument, and also, the piece is a substantial addition to literature for bass clarinet alone. Both Lawrie Bloom of the Chicago Symphony and Edward Palanker of the Baltimore Symphony recommend the Bach cello suites for students first learning the bass clarinet. This is recommended as a Level 3 work.

Becker, Günther. *Once upon a Time: für Bass-Klarinette in B*. Bad Schwalbach: Edition Gravis, 2001.

Becker's early works prior to 1960, were similar in style to Paul Hindemith and Florent Schmitt; however, *Once upon a time* was written when he was embracing Dadaism, distancing himself from his early style. This work

would be a great introduction to new music since the entire piece incorporates extended techniques, includes harmonics, double tongue, flutter tongue and quarter tones. Although there are several instances where the bass clarinetist must play in the altissimo range, it is mostly written in the low to clarion range. The piece is written in French notation, a low C instrument is required, and it is recommended for Level 3.

Berio, Luciano. *Sequenza IXc for Bass Clarinet*. New York: Universal Edition, 1998.

This is an advanced work composed mostly in bass clef. The piece does not require extended techniques, but it requires a great amount of control from the bass clarinetist, especially with regard to dynamics, color and tone. It is a beautiful work that should be considered as a staple in the bass clarinet repertoire and is recommended as an advanced Level 4 piece.

Busch, Adolf. *Suite für Bassklarinette oder Klarinette solo*. Winterthur: Amadeus Verlag, 1980.

Adolf Busch was a violinist and composer who, during the 1930s, established the Busch Chamber Players, known for their performances of Bach's Brandenburg Concertos. As a composer he was influenced by Max Reger. The influence of these two musical styles can be found in this five movement piece which is a bit challenging and could be considered an early Level 3 piece. There are no extended low notes in this piece, but it does incorporate the clarion register and the altissimo register in later movements. Composed in the Baroque style, this would be a great preliminary work before introducing the Bach cello suites.

Carter, Elliot. *Steep Steps for Solo Bass Clarinet*. Milwaukee: Boosey & Hawkes, 2001.

Premiered by Virgil Blackwell in 2000, the title *Steep Steps* refers to the over-blown twelfth of the clarinet and bass clarinet and forms the basis of the piece. Rhythmically and technically demanding, this piece is best for advanced Level 4 students and would also serve as a work for Level 5. The piece does not incorporate extended techniques, but instead, highlights the extreme registers of the bass clarinet, requiring a great deal of control voicing the low and altissimo notes.

Dorff, Daniel. *In A Deep Funk: Dance Set for Solo Bass Clarinet*. King of Prussia: Theodore Presser Company, 2014.

This is appropriate for a Level 2 bass clarinetist. While the rhythms can be tricky, they are often repetitive and have a driving groove. The work has four movements; "Hustle Mysterioso," "Twist Variations," "Bear Hugs," and "Funk Scherzo." Each offers a different style of "funk." There are a few altissimo notes, but most of the piece remains in the chalumeau and clarion range. An extended range instrument is required.

Gabriel, Wolfgang. *Sonata, Op. 72*. Tacoma: Alea Publishing, 2003.

Composed for Michael Davenport, this is a very interesting work by Gabriel. It is not as technically challenging as his works for bass clarinet and piano, but much of the piece incorporates the extremely-high range. The work is more tonal than his previous pieces and it is comprised of four movements: "Toccata," "Andante con Variazioni," "Scherzo," and "Passacaglia." Unique to this piece are sections of the score in which the bass clarinet is essentially playing a duet alone. In these sections the melody spans the bass and treble clef so that the player must alternate between two lines, the top line in treble clef, and the lower line in bass clef. Because of the transitions from bass to treble clef, this is excellent for Level 4.

Genzmer, Harold. *Sonate für Bassklarinette solo*. Leipzig: Henry Litoff's Verlag/C.F. Peters, 1984.

Composed in French notation, this piece has multiple meter changes and takes advantage of the extremely low and altissimo range requiring a low C instrument. No extended techniques are required. However, the piece is very demanding technically. An advanced Level 3 player could play this piece as well.

Hartzell, Eugene. *Monologue 13: Configurations for Bass Clarinet*. Vienna: Doblinger, 1983.

This work does not require extended techniques but it does incorporate the altissimo range of the bass clarinet throughout, often beginning after rests when proper voicing is critical. A low C instrument is required and this is a Level 5 piece.

Hyla, Lee. *Mythic Birds of Saugerties for Solo Bass Clarinet in B flat*. New York: Carl Fischer, 2010.

As with the bass clarinet concerto, the influence of punk rock is not lost on Hyla's composition for bass clarinet alone. The composer takes advantage of the full range of the instrument, including the extremely-high range. Extended techniques are prevalent throughout, requiring harmonics, flutter tongue, and glissandos. Although ranked at Level 5, an advanced Level 4 student could also perform this work. This piece, written for Tim Smith, "is a tribute to the birds of upstate New York."

Karlins, William M. *Improvisations on "Lines Where Beauty Lingers" for Solo Bass Clarinet*, King of Prussia: Tritone Press, 2002.

A mix of classical and jazz styles, this piece was written for clarinetist and bass clarinetist Richard Nunemaker. The work calls for slap tongue and vibrato. Rhythms are complex and there is frequent use of the altissimo range. No

improvisation from the performer is required. In fact, the composer includes detailed instructions throughout. This is recommended for Level 4.

Mandat, Eric. *Chips Off the Ol' Block*. Cirrus Music, 1999.

This piece was premiered by Eric Mandate on a faculty recital at Southern Illinois University Carbonale on April 14, 1999. The work is composed of several motives which are stated alone and then develop and expand to eventually become the “super motive,” which “eventually [dissolves] into a fiery cauldron of reckless abandon.” Multiphonics, altissimo and extremely-high notes are required, as well as a low C instrument. The piece does not have a time signature and occasionally omits bar lines. Mandat includes performance considerations and notes the 16<sup>th</sup> note = 16<sup>th</sup> note throughout. He also includes fingerings and suggestions for multiphonic notes. This is recommended as a Level 5 piece, but could also serve as an advanced level 4.

Martin, Theresa. *Grit'n Grind*. Louisville: Potenza Music Publishing, 2013.

This piece demands extreme proficiency of the low register, especially the extended keys. Appropriate for an advanced Level 2 student or a student at Level 3, *Grit'n Grind* includes repetitive rhythms in an etude like fashion. Alternating note groupings of twos and threes allows for unexpected accents, creating the feel of an off balance “groove.” A fun yet challenging piece for recital.

Martino, Donald. *Strata; Bass Clarinet Solo*. Cincinnati: Apogee Press, 1967.

Extended techniques are prevalent throughout, along with extreme register, meter and tempo changes. *Strata* is composed for a bass clarinetist who has mastered all technical and voicing challenges of the instrument and has a clear understanding of extended techniques. This is advised for graduate and professional bass clarinetists at Level 5.

Opperman, Kalmen. *Un Seul for Clarinet in B flat or Bass Clarinet in B flat*. New York: Carl Fischer, 2000.

Composed for Richard Stoltzman, this piece is reminiscent of Italian opera or the etudes of Cavallini, but less technically difficult. By incorporating standard scales and chord patterns, traditional techniques and musical interpretations are emphasized. There are no notes lower than the low E, although some sections can be taken down the octave if students have access to an extended range instrument. One area of difficulty that may not yet be introduced, but can be taught, is the altissimo range which Opperman does not shy away from in this work, the highest note being altissimo A. Recommended for advanced Level 2 and 3 students.

Peterson, Geoffrey. *Homage to Donald Erb: for Solo Bass Clarinet*. King of Prussia: Tenuto Publications, 2002.

Composed for fellow composer Daniel Dorff, *Homage to Donald Erb* is a work suitable for students at Level 3 or advanced Level 2. The piece is not terribly long, with a duration of approximately four minutes. Composed in French notation, it is not demanding in the altissimo range, only extending as high as the altissimo D; however, the piece takes advantage of the extended low range, calling for low Ds, D flats and several low Cs. Although tempos are not extremely fast, a great deal of musical sensitivity is required with regard to tempo changes and dynamics.

Schaffer, Boguslaw. *Monolog*. Vienna: Ariadne Verlag, 1980.

Written for, and dedicated to Harry Sparnaay, this piece embodies new music and extended techniques. Fingerings are included for German system bass clarinets along with precise instructions and inventive, modern notation. Harry Sparnaay's book *The Bass Clarinet: A personal history* would aid in learning this piece. This is appropriate for graduate students and professionals, Level 5.

Sciortino, Patrice. *Sillons: 3 Studies for Bass Clarinet Solo*. Paris: Gérard Billaudot Éditeur, 1991.

This is a Level 4 work that requires a low C instrument and expands into the altissimo range, and there is no use of the extremely-high range. The piece is rhythmically challenging and the first movement "Sillon I" does not include bar lines. A variety of articulations are necessary, such as slap tongue and flutter tongue. The second movement "Sillon II" does include meter changes, often at every bar, and wide leaps, usually of an octave, are incorporated throughout. The final movement, "Sillon III" is equally demanding and involves flourishes that span the entire register of the bass clarinet.

#### Clarinet Literature and Studies also for Bass Clarinet

Manevich, Alexander. *Ten Studies for Clarinet*. Edited by Stanley Drucker. New York: International Music Company, 1967.

The Manevich studies were recommended by one of the participants in the study. These, along with etudes by Cyrille Rose are often used for bass clarinet as well. They are technically challenging and incorporate much of the altissimo range. For bass clarinetist, these studies would help establish bass clarinet altissimo fingerings and could be introduced at Level 3 and emphasized for Level 4 bass clarinetists.

Ruggiero, Giuseppe. *Huit études atonales: pour clarinette*. Paris: A. Leduc, 1970.

This study was a suggestion from an individual who completed the questionnaire for this dissertation, and it is excellent for students learning contemporary music. All of the exercises have multiple shifts in meters, are rhythmically challenging, and are atonal. Techniques such as flutter tongue, glissandos, and vibrato are incorporated throughout. This is recommended for Level 4 and 5.

Stravinsky, Igor. *Three Pieces for Clarinet Solo*. London: Chester Music, 1993.

While this piece was originally composed for clarinet, participants from the interviews suggested it as a transitional piece from clarinet to bass clarinet. This is recommended for Level 4 and Level 5.

Schumann, Robert. *Fantasiestücke : für Klarinette*. Wiesbaden: Breitkopf & Härtel, 2006.

Two of the participants from the interviews suggested this as a solo work to play on bass clarinet, and works well for students learning to double. This is suggested for students at Level 4.

Tower, Joan. *Wings: for Solo B-flat Clarinet or Bass Clarinet*. New York: Associated Music Publishers, 1983.

Tower's *Wings* is an advanced work for clarinet, which can be performed on bass clarinet. This piece requires a great amount of control in all ranges, and extreme dynamic contrasts. A solid foundation in fundamentals is needed to perform this piece, and it is appropriate for students at Level 5.

## **Chapter 4**

### **Questionnaire Results and Suggested Course of Study for the Incorporation of the Bass Clarinet into the Clarinet Studio**

#### Questionnaire Format and Procedure

Twenty-five questionnaires were emailed to bass clarinet soloists, teachers who specialize in bass clarinet, teachers who incorporate bass clarinet into the studio, and pedagogues who teach traditional clarinet studios. Those who participated are leading pedagogues of major universities both in the United States and internationally, international soloists and specialists, and bass clarinetists who hold positions in major symphony orchestras across the United States. Of the twenty-five questionnaires emailed, thirteen were returned and three of the participants requested phone interviews.

The questionnaire was divided into three sections: 1) “General Questions” about perspectives on teaching bass clarinet and including it as a part of the studio curriculum, 2) “Equipment,” which was further divided into instruments and mouthpieces, and 3) “Literature,” which was further divided into methods and studies, orchestral excerpts, solo with accompaniment, bass clarinet alone, and chamber music. The questionnaire was in a check box format. For general questions, participants could choose “strongly agree,” “agree,” “disagree,” or “strongly disagree.” Equipment selections could be checked and rated one through five, one being most practical and five least practical. Methods and literature were checked “yes” if the participant used it, “no” if he or she did not, and “unknown” if they were unaware of the piece. Additional space for comments was provided at the end of each section. Following the results of the questionnaire is a

conclusion, which summarizes the information and discusses how it has been applied to the suggested course of study.

### General Questions

When asked if learning bass clarinet is helpful to a student's career, all participants agreed or strongly agreed. All agreed that the bass clarinet should be included as a regular part of the clarinet curriculum. However, when asked if all clarinetists should also learn bass clarinet, three participants disagreed, five agreed, three strongly agreed, and one did not answer. Although the majority agreed, there is still hesitation with regard to whether or not all students should learn bass clarinet. Many of the participants offered valid explanations for their reasoning on the subject.

#### Comments:

- "Bass clarinet should be included, along with the other harmony clarinets, in any college clarinet curriculum."
- "Regarding Question 3, I'm not sure if all clarinetists should learn to double. Deep down, as a doubler, I'm inclined to strongly agree. However, it depends on what level student we're talking about."
- "I disagree with 3 because there are some clarinetists who really don't want to play the bass. And I think it's quite 'stupid' to force them to do so."

When asked if more schools should offer specialization in bass clarinet, six participants strongly agreed, two agreed, four disagreed and one did not answer.

Comments:

- “Regarding question 4, I don’t agree whole-heartedly with having more specialized programs available at the college level. I do agree with offering degrees in its performance and having the opportunity to study with someone who is proficient on the instrument. Because doubling is becoming more common, the bass clarinet (and the rest of the clarinet family, for that matter) should simply be integrated in the curriculum for the entire clarinet studio. Having the opportunity to perform in a university clarinet choir gave me the chance to sample every instrument. This is enough of a reason to organize and maintain an ensemble like this on campus. Some schools have done away with their clarinet choirs, not realizing that this ensemble is crucial to the development of well-rounded clarinet players.”
- “I have always been a bass clarinet specialist that doubles on clarinet. Because the repertoire is substantial on bass clarinet and [it] really has become a contemporary instrument, I believe that students should be able to specialize on bass clarinet as their main instrument. I believe they should be able to do this without only having the opportunity as a doubling clarinet student that only takes up the instrument for better job opportunities. I know very few doubling clarinetists that truly know the bass clarinet, understand the repertoire, and have properly developed the different technique[s] of the bass clarinet.”
- “I do not think schools should offer a specialization in bass clarinet. When taking a bass clarinet audition, clarinet is a very important part of the audition. Bass clarinet should always be treated as a double. If a player wishes to specialize on

bass later, then more serious study of bass comes into play. Even so, the player is always a clarinetist (Bb, A, Eb) first.”

When asked at what point a clarinetist should begin doubling on bass clarinet, participants had the option of answering with the following choices: “never,” “high school,” “freshmen,” “sophomore,” “junior,” “senior,” “graduate school,” “depends on the student,” and, “only if the student shows interest.” Three participants answered “depends on the student,” two answered “only if the student shows interest,” one answered “senior/grad. school,” three answered “junior,” two answered “sophomore,” one answered “freshmen,” and one answered “high school.”

Comments:

- “Should all high school clarinetists learn bass clarinet? Perhaps not. It’s hard enough to teach the section to play the soprano well. Instead of encouraging poor soprano players to pick up the instrument (as many programs tend to do), take a couple top players and give them time every week to devote to the bass clarinet. Then alternate them between principal, bass, and first-part soprano roles...” “So, I believe learning the bass clarinet needs to begin in high school, but not everyone should do it. What about college? Should all college-level clarinetists learn the bass clarinet? Yes, especially those seeking performance degrees. Those seeking education degrees would benefit greatly as well.”
- “When to start? That is up to the student. However, all incoming college freshman should be required to play bass and contra-bass, alto, and Eb in the band/wind

ensemble. If the school only has orchestra—then in orchestra. And, always, encourage students to study with the local bass [clarinetist].”

## Equipment

### *Instruments*

Participants were asked which brand of instrument they most recommend for university programs and were given a rating system of one through five, one being most practical and five being least practical. The selection of instruments are as follows:

Amati ACL 6925 (low C)

Buffet Prestige BC 1183 (low E-flat)

Buffet Prestige BC 1183 Greenline (low E-flat)

Buffet Prestige BC 1193 (low C)

Buffet Prestige BC 1193 Greenline (low C)

Buffet Tosca Bass Clarinet BC 1195 (low C)

Selmer Model 65 (low E-flat)

Selmer Privilege Model 67 (low C)

Yamaha YCL-622II (low C)

Yamaha YCL-621 (low E-flat)

The Buffet Prestige BC 1193 (low C) was ranked most practical by eight out of thirteen participants. This was followed by the Buffet BC1193 Greenline (low C) with seven of the participants ranking it as most practical, and the Selmer 67 (low C) had six

out of thirteen votes. The Buffet Tosca 1195 (low C) had four, the Buffet Prestige E-flat and the Yamaha low C bass clarinets each had three votes, and the Amati, Selmer 65 and Yamaha low E-flat each had one vote as most practical. The Buffet Prestige BC 1183 Greenline (E flat) did not have any votes as most practical, and was ranked in the middle range.

Comments:

- “The Selmer and Buffet bass clarinet go out of adjustment too easily in our school’s inventory.”
- “I play a Yamaha YCL-622II, so obviously I will recommend that model. I’ve played Selmers and Buffets before and love them, but I’ve never played an Amati, so I rate the Amati high only because it is a low C instrument. I don’t believe that bass clarinets to low E-flat are practical for university programs. If the college marching band marches bass clarinets, then yes, use plastic horns to low E-flat. Or if you have some sax players who want to get inside Dolphy’s head, by all means use a horn to low E-flat. But if you are filling the instrumentation for wind ensembles and orchestras, you need low C instruments. I know many high school programs now have at least one professional instrument to low C.”
- [In reference to the Buffet Prestige BC1193 low C, and Buffet Prestige BC1193 Greenline low C] “with the remark that this doesn’t mean that those are the only good ones. For me personally I like them more and I played till my pensioning on them.”

- “I am personally not a fan of the Yamaha bass clarinets. For the price, I believe these are significantly inferior to the Buffet and Selmer clarinets.”
- “A Low C bass clarinet has become essential to be able to play much of the repertory. Nowadays most of the composers assume that is its normal range. Although a Low E-flat instrument seems to be the best choice for a wind band class, it'll be impossible with it to have a satisfactory bass clarinet class, since much of the repertory won't be playable.”
- “Yamaha is better than before, but not on the same level as Selmer and Buffet. Investments in these horns [are] important, but equally important is maintaining them—getting them in the shop to be worked on each year.”
- “Obviously, this would depend on the university/college music department budget.”
- “I don't know the Amati. I haven't played Yamahas in over 15 years, and may not know the most contemporary models. While the decision between Selmer and Buffet is largely personal, I have found that Buffets tune better and have more stable mechanism; Selmers have a characteristic sound I like very much but are less flexible/in tune.”
- “I cannot emphasize this strongly enough; it is the band director's/private teacher's responsibility to make sure the instrument is always in proper adjustment. There should be a repair person that the band and/or private instructor works with who would be responsible for the repair work. It is always better if the same person works on the horn all the time. There should be a financial arrangement made with the repair shop so that the student is able to take the horn over, have the work

done in a timely fashion, and not have to worry about cost. Also, it should be the band director's/private teacher's job to make sure the student has a first class mouthpiece (that the student owns! Along with their own ligature and cap!). Also, the correct reeds and reed strength for that particular mouthpiece. Having quality equipment for bass clarinet is 75% of being able to play the instrument well. Consistent practice and study is the other 25%.”

### *Mouthpieces*

The participants were asked which mouthpieces they most recommend and then asked to rank them according to what would be most practical for a university program. Selections include: Bay, Behn, Fobes Debut, Fobes Nova, Fobes San Francisco, Hawkins, Pyne, Selmer C85 (tip openings 105, 115, and 120), Selmer Concept, Selmer Focus, Selmer C\*, Vandoren (models B40, B44, B45, B46 and B50).

The most recommended mouthpiece was the Selmer C\* with eight of the thirteen votes as most practical for a university program. Vandoren had six votes as most practical, and the most recommended models were the B45 and B50. The Selmer Focus, Concept and C85 each had five votes as most practical for a university program. The most recommended tip openings for the C85 are 120 and 115. The other mouthpieces were not as highly recommended, usually due to cost, especially with regard to purchasing equipment for a college program. Many participants recommended other mouthpieces for consideration that I was unaware of prior to constructing the questionnaire. Their comments and recommendations are below.

Comments:

- “I recommend the Fobes mouthpieces, as he does a fine job of manufacturing and finishing them. I played on a San Francisco for many years until I switched to the Backun. I recommend the Backuns highly. However, it is very expensive for colleges and students.”
- “Bass clarinet mouthpieces tend to be very expensive. Since every player should own their own rather than share the one that comes with the instrument they will undoubtedly share, it should be their preference (decided upon after consulting with their instructor). I have loved the consistency of Selmer and Vandoren mouthpieces. They are predictable and often less expensive than the others you listed.”
- “In my humble opinion, it is so important that the teacher teaches to the pupils the way to understand the importance to find the right reed strength related to the opening of the mouthpiece to obtain a rounded, warm sound.”
- “This was a selection for my students who were specializing in contemporary music. I heard that the Fobes mouthpieces are also great. In fact the real selection would be Selmer F, but I don’t think it [still] exists.”
- “Selmer C\* and C\*\* are very popular in Spain and, through my experience, they give good results as a high-quality mouthpiece for beginners (and professional players). Vandoren B45 and B50 have also good results with students (and professional!), and I also recommend them. Selmer and Vandoren are easy to find and they have a reasonable price. Pomarico and Viotto are also a popular choice for professional bass clarinetists. I play with a Pomarico, custom made facing.”

- “The Pine and Fobes are good, but sometimes pitch can be an issue. And finding reeds for them can also be an issue. Ultimately, price is also an issue, so that is why I stay with Selmer and Vandoren-consistency and price.”
- “There are many excellent mouthpieces on the market. Selmer C\* continues to be the most reasonably priced and most consistently good mouthpiece out there.”
- “I prefer for high school students a Selmer C\* reworked by Rick Sayer (in Chicago). For more advanced high school and college students I like the Walter Grabner LB model or the Selmer Focus. Medium tip opening. Reeds: #3.0 or 3.5 Vandoren V-12 or #4 Rico Classic.”
- “I know the Fobes by facing names/letters (CF or RR are the ones I know), so I'm not sure which Fobes these refer to. In general I would recommend his work. I would consider getting a "custom" mouthpiece for a college program, and I notice you did not include the Grabner mouthpieces, which are pretty consistently good. Selmer C\*s lend themselves to refacing, but I don't know if I'd just get any old stock C\*... Ramon Wodkowski can make a very good bass clarinet mouthpiece. I don't know the other models you list above.”

## Literature

### *Methods*

Some participants were familiar with all the bass clarinet methods, some knew and used a few of the methods, and some participants were not familiar with bass clarinet methods, as they used clarinet methods for studying bass.

The methods and guides most used for bass clarinet were Harry Sparnaay's *The Bass Clarinet: A Personal History*, Jean-Marc Volta's *The Bass Clarinet (Method)*, and Sauro Berti's *Venti Studi*. Six of the thirteen participants said that they used and taught from these books: *Studies for Bass Clarinet*, Volumes 1 and 2 by Pedro Rubio, *New Techniques for the Bass Clarinet* by Henri Bok, and *18 Selected Studies for Alto and Bass Clarinet* were used by five of the participants. Comments were provided and suggestions for other texts were also provided (see Table 9).

Table 9. Questionnaire Results: Bass Clarinet Method Books

Book	Participants													Total	
	1	2	3	4	5	6	7	8	9	10	11	12	13		
Arnold, <i>Scale Book</i>			X	X	X										3
Berti, <i>Venti Studi</i>			X	X	X	X	X	X							6
Bok, <i>New Techniques for Bass Clarinet</i>	X	X	X			X	X								5
Davenport, <i>Etudes for Bass Clarinet</i>			X	X									X		3
Pellegrino, <i>Short Synopsis on the Bass Clarinet</i>			X												1
Rhoads, <i>18 Selected Studies</i>			X	X		X		X	X				X		6
Rhoads, <i>Advanced Studies- from Weissen born</i>			X	X				X	X				X		5
Rhoads, <i>Baermann for Alto and Bass Clarinet</i>			X	X		X							X		4
Rhoads, <i>Etudes for Technical Facility</i>			X	X									X		3
Rhoads, <i>Foundation Studies</i>			X	X									X		3
Rhoads, <i>Technical Studies</i>			X	X		X							X		4
Rubio, <i>101 Studies for Bass Clarinet Vol. 1</i>			X	X	X		X	X							5
Rubio, <i>101 Studies for Bass Clarinet Vol. 2</i>			X	X	X		X	X							5
Sparnaay, <i>The Bass Clarinet: A Personal History</i>		X	X	X	X	X	X								6
Volta, <i>The Bass Clarinet (Method)</i>	X		X	X	X		X	X							6

Comments:

- “The Volta book is all you need.”
- “All of these texts are excellent. The Rhoads are a little outdated and focus more on the typical range found in studies for the soprano clarinet, although these are useful as introductory studies for the bass clarinet. I also use my own: *Integrated Exercises for Clarinet and Bass Clarinet*, and I encourage my students to compose their own exercises.”

- “I strongly recommend the Volta method and the Rhoads suite of studies.”
- “You can add the studies by Ruggiero (8 atonal studies) and the ones by Manevich.”
- “Apart from my studies books, I use the Berti studies and many interesting studies and pieces written by and for the Italian bass clarinetist Paolo de Gaspari (www.farandola.eu). The H. Bok is a good reference book for advanced techniques, and the Sparnaay has a lot of interesting and useful information, although it's not strictly a study book. The best bass clarinet method that I know is the one by J. M. Volta, excellent.”
- “When I studied with Laurie Bloom (CSO), he had me playing out of the regular clarinet etude literature - Rose Studies & Baermann Daily Studies.”
- “I do not use bass clarinet methods. I use Baermann Bk. III and Rose studies. If you can play these on bass you can play anything. For advanced technique Harry Sparnaay, *The Bass Clarinet*.”
- “I don't use any of them. I have students play their own scale patterns or reduced--range versions of the Baermann and/or Hameline scales.”

### *Orchestral Excerpts*

Participants were asked which books they most used for orchestral studies. Drapkin's *Symphonic Repertoire for the Bass Clarinet*, Vols. 1, 2, and 3 are used by twelve of the thirteen participants. Table 10 shows the books most used when teaching orchestral excerpts.

Table 10. Questionnaire Results: Bass Clarinet Orchestral Excerpt Books

Books	Participants													Total
	1	2	3	4	5	6	7	8	9	10	11	12	13	
Bourque, <i>Bass Clarinet Workbook</i>			X	X				X						3
Drapkin, <i>Symphonic Rep. Vol. 1</i>	X	X	X	X	X	X	X	X	X	X	X	X	X	12
Drapkin, <i>Symphonic Rep. Vol. 2</i>	X	X	X	X	X	X	X	X	X	X	X	X	X	12
Drapkin, <i>Symphonic Rep. Vol. 3</i>	X	X	X	X	X	X	X	X	X	X	X	X	X	12
Giampieri, Book 1	X		X				X	X		X	X			6
Giampieri, Book 2	X		X				X	X		X	X			6
Hepp and Rohde, <i>Orchester Probespiel</i>	X	X	X								X			4
Bartholomey <i>Strauss Orchestral Excerpts Vol. III</i>	X	X	X	X			X			X	X	X		8
Hinze, <i>Wagner Orchestral Excerpts</i>	X	X	X	X						X	X	X		7

Participants were asked which excerpts they most recommend for a first year bass clarinetist.

Comments:

- “Grofe Grand Canyon Suite, Mahler 4.”
- “If it’s first-year performance-track players, get them started on the ones most often found on auditions, like Ravel, Grofe, Wagner, Strauss, Mahler, Shostakovich. First-year high school players might see difficult passages from the wind literature, like Ticheli or Gould.”
- “I strongly recommend Verdi's Ernani, Tchaikowsky's Nutcracker Suite.”
- “I tend not to focus on excerpts, as this is something more for doubling clarinetists. As a bass clarinet specialist, a full-time career as a symphonic musician is not overly practical due to the fact that the repertoire is all modern. I focus more time on solo and chamber repertoire for bass clarinet.”
- “Grofe: On The Trail, Strauss, excerpts, Rachmoninoff Symphony #2 and Symphonic Dances. Anything in bass clef and in A and C. Learn to transpose and read in bass clef.”

- “I wouldn't have a "first-year" bass clarinet major, but if a student is going to study orchestral repertoire, I would suggest starting with the most standard works with an eye to eventual orchestral auditions, also to be ready to play the most-performed works in orchestras: Wagner (Tristan and Rhinefarht), Strauss (Till' and Quixote), Mahler (1, 9), Ravel (Daphnis), Shostakovich (violin concerto, symphony 6) and Stravinsky (Rite, Petrushka). To that I would add the particular works that are most often on auditions: Grofe, Khatchaturian, Nutcracker, maybe Prokofiev Romeo and Juliet, Hindemith Metamorphoses, Schumann #3., etc.”

*Solo Literature with Accompaniment: Original and Transcribed Works*

Participants were asked which solo literature with accompaniment they most used when teaching bass clarinet and they selected works from those shown in Table 11. Works not selected were either unknown or not used for teaching. Eugene Bozza's *Ballade* was the most selected by eleven out of thirteen participants. Othmar Shoeck's Sonata Op. 41 was selected by nine of the participants as was Yvonne Desportes's *Andante and Allegro*. Michael Kibbe's Sonata Op. 41 and David Bennet's *Deepwood* was selected by seven participants.

Following the section about solo literature, participants were asked which pieces they considered to be most standard for bass clarinet repertoire and to include any not listed. Additional suggested pieces are *Duo* by Gary Kulesha, *Jackdaw* by Wayne Siegel, *Spasm* by Michael Lowernstern, *Concerto for bass clarinet and orchestra* by Dietrich Erdmann, Sofia Gubaidulina's *Punkte, Linien, und Zickzack (Points, Lines, and ZigZags)* and Joseph Schelb's *Concerto for Bass Clarinet and 10 Instruments*.

Table 11. Questionnaire Results: Bass Clarinet Solos with Accompaniment

Composer, Title	Participants													Total
	1	2	3	4	5	6	7	8	9	10	11	12	13	
Bennet, <i>Deepwood</i>			X	X	X	X	X	X	X	X				7
Beyer, <i>Suite for Bass Clarinet and Piano</i>														0
Boni, <i>Largo and Allegro</i>						X								1
Borne, <i>Fantaisie Brillante sur Carmen</i>														0
Brossé, <i>Elegy</i>				X	X	X	X			X			X	6
Brossé, <i>La Soledad</i>				X	X	X	X						X	5
Bozza, <i>Ballade</i>	X	X	X	X	X	X	X	X	X	X		X	X	11
Carter, <i>Concertino for Bass Clarinet and Chamber Orchestra</i>		X	X	X	X				X					5
Desportes, <i>Andante and Allegro</i>	X	X	X	X	X	X	X		X	X		X		9
Diehe, <i>Romanze</i>				X	X	X	X							4
Dykstra, <i>Two Rags</i>				X										1
Eccles (trans. Goldberg), <i>Sonata in G minor</i>						X		X	X			X		4
Favoreel, <i>Zebus</i>				X	X									2
Gabriel, <i>Ballade Op. 23</i>			X	X	X		X							4
Galliard, <i>Adagio and Allegro</i>	X	X	X			X			X	X			X	7
Hyla, <i>Concerto for Bass Clarinet and Orchestra</i>			X											1
Kibbe, <i>Fantasy Sonata Op. 208</i>			X	X					X	X		X		5
Kibbe, <i>Night Music Op. 175</i>			X	X					X	X		X		5
Kibbe, <i>Sonata Op. 40</i>			X	X		X	X		X	X		X		7
Linke, <i>Prozession</i>														0
Nedbal, <i>Sonatine</i>				X			X							2
Rubio, <i>Romanza</i>				X	X		X	X	X					5
Petit, <i>Solipse I</i>			X											1
Prinz, <i>Nachstück (Night Piece)</i>			X	X			X		X					4
Prinz, <i>Sonata</i>			X				X		X			X		4
Proctor, <i>Lyrical Concerto</i>														0
Rasse, <i>Lied</i>			X	X	X		X							4
Schoeck, <i>Sonate Op. 41</i>	X	X	X	X	X	X	X				X	X		9
Russell, <i>Sonata</i>			X	X	X	X	X							5
Schumann, (trans. Volta) <i>Adagio and Allegro Op. 70</i>	X		X			X			X			X		5
Schumann, (trans. Volta) <i>Fünf Stücke im Volkston Op. 102</i>	X		X					X	X		X			5
Sciortino, <i>Calamus, Concerto for Bass Clarinet and Instrumental Ensemble</i>				X	X		X							3
Sciortino, <i>Le Semainier</i>				X	X		X							3
Semler-Collery, <i>Legende et Divertissement</i>				X	X		X						X	4
Sluka, <i>Sonata</i>				X	X		X							3
Söll, <i>Lumen</i>				X	X	X	X							4
Termos, <i>Nieuw Werk</i>		X	X	X										3
Thys, <i>A Gipsy Ludo</i>				X	X									2
Toda, <i>A Sketch</i>				X	X									2
Dorsselaer, <i>Tyl Uylenspiegel</i>				X	X									2
Vejslev, <i>Duet for Bass Clarinet and Piano Op. 121</i>			X	X										2
Vivaldi, (adapted by Bontoux) <i>Concerto in la mineur</i>			X	X				X				X		4
Zander, <i>Ballad</i>				X										1

Comments:

- “I would have included the concerto by Erdmann. Also, the transcriptions by Volta.”
- “Bennett, Bozza, Desportes, Kibbe (all), Gabriel, Prinz, Gubaidulina - Punkte, Linien, und Zickzack, Schoeck, Rubio”
- “Sluka's Sonata, Schoeck's Sonata and all the pieces written before 1945. All the Sciortino's works are important to open the mind of a student and to widen his/her skills.
- “I strongly suggest the Joseph Schelb's Concerto for Bass Clarinet and 10 instruments.”
- “The Bozza Ballade, Duo by Gary Kulesha, Jackdaw by Wayne Siegel, Spasm by Michael Lowernstern.”
- “Standard works: Bozza, Ballade/Semler-Collery, Legende et.../Sluka, Sonata/Schoeck, Sonata/Rasse, Lied/Kibbe, Sonata/Gabriel, Ballade/Desportes, Andante et Allegro/Bennet, Deepwood/Hindemith, Sonata/Kees Vlak, Concerto.”
- “I really cannot answer this with credibility. My experience has been with orchestra music and commissioned music. I always use the Bach Cello Suites for warm-up and solo performance for my students.”
- “I don't know many works for bass clarinet and piano, but I can definitely recommend "Broken Mirror of Memory" by Paul Cantrell (winner of the ICA bass clarinet solo competition). I have students play parts of the Schuman Fantasy Pieces, the Gade Fantasy pieces, the Vaughan-Williams studies, the Saint-Saens

bassoon sonata, parts of the Hindemith clarinet sonata, all of the Hindemith bassoon sonata.”

### *Bass Clarinet Alone*

From the list of solo pieces for bass clarinet alone shown in Table 12 the Genzmer *Sonata for Bass Clarinet* was selected by ten of the thirteen participants, nine participants selected Eric Mandat’s *Chips Off the Ol’ Block* as a piece they taught, and seven selected Berio’s *Sequenza IXc*.

Participants were asked which pieces they considered to be most standard for bass clarinet solo literature, including anything not listed. Twelve of the participants responded with comments. Of the twelve, six stated the Bach cello suites as one of the most standard pieces for solo bass clarinet. Other solos mentioned that were not included in the questionnaire are *Press Release* by David Lang, *Soft* by Franco Donatoni, *Monolog* by Isang Yun, *The First Sea* by Michael Matthews, *Little Girl Blew* by Harry Freedman, *Itou* by Pascal Dusapin, *Partial Truths* by Evan Ziporyn, *Sprezzatura* by Guus Janssen, *Solo Identity 1* by Jos Kunst, *Chimeara* by Enrique Raxach, *Child* by Mauro Cardi, *Écoute,écoute!* and *Yuxtaposiciones* by Roderik de Man, *Twist* by Gerard Brophy, *In freundschaft* by Karlheinz Stockhausen, and *Oculto* by Luis De Pablo.

Table 12. Questionnaire Results: Bass Clarinet Alone

Composer, Title	Participants													Total
	1	2	3	4	5	6	7	8	9	10	11	12	13	
Adamík, <i>Monolog</i>				X	X									2
Adamík, <i>Structures oc the Obsession</i>				X	X									2
Adler, <i>Clarinon</i>				X						X		X		3
Ambrosini, <i>Capriccio detto L'Ermafrodite</i>		X	X	X										3
Aurbach, <i>Prayer</i>														0
Bach, (trans. Sargent) <i>Allemande and Courante From Suite #1 for Cello</i>	X	X		X	X					X				5
Babitt, <i>My Ends are My Beginnings</i>		X	X	X	X					X				5
Baur, <i>Sechs Bagatellen (Vogelrufe)117</i>		X	X	X								X		4
Berio <i>Sequenza IXc</i>	X		X	X	X	X	X		X		X			7
Brophy, <i>NRG</i>		X	X	X	X	X								4
Busch, <i>Suite Op. 37</i>			X	X	X	X			X		X			6
Cardew, <i>Mountains</i>		X		X										2
Carter, <i>Steep Steps</i>		X	X	X	X	X								5
Cole, <i>Excursions, Variations on a theme of Paganini</i>							X							1
Davidson, <i>Jump</i>				X		X								2
De Luca, <i>Komuso</i>														0
Dorff, <i>Flowers of St. Francis (Five Scenes for Solo Bass Clarinet)</i>				X									X	2
Dorff, <i>In a Deep Funk Dance Set for solo Bass Clarinet</i>				X									X	2
Dubois, <i>Voltage Suite for Solo Bass Clarinet Max</i>			X	X	X	X								4
Erdmann, <i>Monolog</i>	X	X	X	X	X	X								5
Ferneyhough, <i>Time and Motion Study I</i>		X	X	X	X	X	X							6
Freeman, <i>Propagations</i>				X										1
Genzmer, <i>Sonata for Bass Clarinet (Solo)</i>	X	X	X	X	X	X	X		X	X	X			10
Globokar, <i>Voix Instrumentalisée for Bass Clarinet (Solo)</i>		X	X	X										3
Hartzell, <i>Monologue 13, Configurations for Bass Clarinet</i>			X	X	X									3
Kagel, <i>Schattenklänge, Three Pieces for Bass Clarinet</i>	X	X	X	X	X	X			X		X			7
Karlins, <i>Improvisations on 'Lines Where Beauty Lingers'</i>				X	X				X		X			4
Mandat, <i>Chips Off the Ol'Block</i>	X	X	X	X			X	X	X		X	X		9
Montilla, <i>Introduction and Joropo</i>			X				X	X	X				X	5
Nyman, <i>Manhatta: For Solo Bass Clarinet</i>				X										1
Sciortino, <i>Clef</i>			X	X										2
Sciortino, <i>Sillons-3 Etudes</i>			X	X	X									3
Shapira, <i>A Talk with the Unseen</i>			X											1
Singleton, <i>Argoru V/a</i>			X	X										2
Vejslev, <i>Four Solos for Bass Clarinet Op. 97, 105, 106, 107</i>			X		X									2
Zander, <i>Capriccio</i>	X	X	X											3

Comments:

- “Bach Cello stuff.”
- “Spasm-Michael Lowenstern, Press Release-David Lang, Soft-Franco Donatoni, any Cello Suites – Bach, Monolog – Isang Yun, The First Sea-Michael Matthews, Little Girl Blew- Harry Freedman, Itou-Pascal Dusapin.”

- “Those marked yes above, and perhaps Press Release by David Lang and Monolog by Isang Yun, or Partial Truths by Evan Ziporyn.”
- “J.S. Bach Six suites for cello transcribed for bass clarinet”
- “Isang Yun - Monolog: Guus Janssen - Sprezzatura: Jos Kunst - Solo Identity 1: Enrique Raxach - Chimeara: Mauro Cardi - Child: Franco Donatoni - Soft:Roderik de Man - Écoute,écoute!: Roderik de Man – Yuxtaposiciones”
- “Little Girl Blew by Harry Freedman, Twist by Gerard Brophy”
- “Any of the Bach cello Suites/Busch, Suite/Berio, Sequenza/Stockhausen, In freundschaft/Kagel, Schattenklänge/Globokar, Voix.../Ferneyhough, Time.../Dubois, Voltage/Davidson, Jump/Cole, Excursions/Carter, Steep-Steep/Brophy, NRG/De Pablo, Oculito/Isan Yung, Monolog”
- “The Adolf Busch solo work is a very good one for serious bass clarinet students to work on. The VonKoch Monologue (for soprano clarinet) is very good on bass, the Osborne as well. Solo Bach (cello suites) would be good to do. The Rivier "Les Trois S" works on bass. Many of Elliot Weggarber's concert etudes work well on bass. Jeanjean's "Arlequin" works... Berio's "lied" works better on bass than his "Sequenza" does.”
- “Bach Cello Suites”

### *Chamber Music*

Of all the chamber music, three stood out as most often taught: Paul Hindemith’s *Wind Septet*, Arnold Schoenberg’s *Pierrnot Lunaire* Op. 21, and Gunther Schuller’s *Duo Sonata*. Each were used by ten of the thirteen participants. Leoš Janáček’s, *Mladi* was

used by nine of the participants. The other pieces were not as well known or used as often when teaching bass clarinet.

Participants were then asked if there were other chamber works they would recommend that were not included in the questionnaire. These include: *Rigmarole* by Elliott Carter, *Oi Kuu* by Kaija Saariaho, *Chiffres* by Wolfgang Rihm, *The Riot* by Jonathan Harvey, *Volo Solo* by Cornelius Cardew, *Spray* by Michael Smetanin, *Hommage à Burri* by Salvatore Sciarrino, *HET* by Franco Donatoni, *HEAD* by Gerard Brophy, *Ringing the Changes* by Andrew Ford, *Mysterium Coniunctionis* by Gary Kulesha, *Chamber Concerto* by György Ligeti, *Stealth* by John Burke, *Phoenix* by Quentin Doolittle, *Berceuses du Chat* by Stravinsky, *Goethe Lieder* by Dallapiccola, works by Roderick de Mann, trios and quartets by Francisco Zumaque, Mozart Divertimenti (originally for 3 basset horns; arr. 2 clarinets and bass), Mozart Adagio (arr. clarinets and one bass), and clarinet quartets such as the Waterson, the DesPortes and the quartet by Alfred Uhl.

Table 13. Questionnaire Results: Chamber Music with Bass Clarinet

Composer, Title	Participants													Total
	1	2	3	4	5	6	7	8	9	10	11	12	13	
Albright, <i>Pit Band</i>				X						X		X	X	4
Argento, <i>To Be Sung Upon The Water</i>			X	X								X		3
Bach, (arr.Schmidt, ed. Davis) <i>Contrapunctus XII</i> (from Art of Fugue)				X										1
Bach, (arr. Schmidt) <i>Contrapunctus XIII</i> (from Art of Fugue)				X										1
Bach, (arr.,Schmidt ed. Davis) <i>Contrapunctus XV</i> (from Art of Fugue)				X										1
Bach, (arr., Schmidt, ed. Davis) <i>Three Inventions</i> (Vol. 1)				X										1
Bach, ( arr., Schmidt, ed. Davis) <i>Four Inventions</i> (Vol. 2)				X										1
Bach,(arr.,Schmidt, ed. Davis) <i>Four Inventions</i> (Vol. 3)				X										1
Bach,( arr. Volta) <i>Inventions</i> (Vol. 1)	X			X				X						3
Bach, (arr. J.M. Volta) <i>Inventions</i> (Vol. 2)	X			X				X						3
Bedoya, <i>Three Duos</i>				X		X		X						3
Bodin de Boismortier, (trans. Rubio) 6 Sonatas for Two Bass Clarinets				X		X	X							3
Bowen, <i>Phantasy Quintet Op. 93</i>	X	X	X	X	X		X							5
Brent-Smith, <i>Trio in D minor</i>														0
Curtis, <i>5 Huapangos</i>				X				X						2
Curtis, <i>8 More Original Jazz Duos</i>				X				X						2
Festinger, <i>Trionometry</i>				X	X									2
Gräbner, <i>Neue Liebe, Neues Leben</i>				X										1
Hefti, ( <i>Traum-Ze(n)it, Dialog for 2 Bass Clarinets</i> )				X	X									2
Heucke, <i>Sonata</i>				X			X							2
Hindemith, <i>Wind Septet</i>	X	X	X	X	X	X	X		X	X	X	X	X	10
Janáček, <i>Mladi</i>	X	X	X	X		X			X	X	X	X	X	9
Kagel, <i>Rrrrrrr ... Five Jazz Pieces</i>		X	X	X	X									4
Kibbe, <i>Pink Flamingos Tango</i>			X	X								X		3
Lloyd, <i>Trio</i>				X										1
Prinz, <i>Figarello's Morningsong</i>			X	X								X		3
Prinz, <i>Meeting</i>			X	X								X		3
Richardson, <i>Trio Sonata</i>				X										1
Schoenberg, <i>Pierrnot Lunaire, Op. 21</i>	X	X	X	X	X	X	X		X	X	X			10
Schuller, <i>Duo Sonata</i>	X	X	X	X	X	X	X		X		X	X		10
Sciortino, <i>Sore</i>				X	X	X								3
Sierra, <i>Tres Pensamientos</i>			X	X			X				X	X		5
Stewart, <i>Old Shoes Op. 54</i>				X										1
Wolpe, <i>From Here On Farther</i>	X	X	X	X					X					5

## Comments:

- “I don't know most of the contemporary stuff, I'm glad to learn of new music that's available, other than what composers write for me. As to your subject, I

usually discourage students from going into Bass Clarinet study in-depth. I feel it's more important to spend their time on the clarinet. I can show them the differences in playing Bass Clarinet, but I expect them to work on that on their own.”

- “Rigmarole-Elliott Carter (bcl/vc), Oi Kuu-Kaija Saariaho (bcl/vc). I’m not a big fan of performing transcriptions. Working on them is great, for it exposes us to styles that are often foreign to us as clarinetists (such as the now cliché Bach cello suites on bass clarinet. I’ve performed them too!). There is too much music now available to us as bass clarinetists (or as doublers), so it is our duty to seek them out and perform them.”
- “Chiffres-Wolfgang Rihm, The Riot-Jonathan Harvey, Het-Franco Donatoni, Volo Solo-Cornelius Cardew, Spray-Michael Smetanin, Oi Kuu-Kaija Saariaho, Hommage à Burri-Salvatore Sciarrino”
- “Franco Donatoni - HET for flute, bass cl. and piano; Gerard Brophy - HEAD for piccolo, bass cl. and piano; Andrew Ford - Ringing the Changes for flute, bass clarinet and piano.”
- “Mysterium Coniunctionis by Gary Kulesha, Ligeti's Chamber Concerto, various pieces by Roderick de Mann, Stealth by John Burke, Phoenix by Quentin Doolittle, etc.”
- “Bodin trans Rubio, Bowen, Curtis 5 Huapangos, Curtis 8 More Original Jazz Duos, Heucke Sonata, Hindemith Septet, Janaceck, Schoenberg, Schuller, Sciortino Sore, Sierra,”
- “Trios and Quartets by Francisco Zumaque”

- “As you can see, I did not really study the great literature of the bass clarinet - solo or chamber music. My sole purpose for studying the bass clarinet was to become proficient enough to freelance (both in the pit and in the symphony orchestra) in the city of Chicago. It is for that reason that I concentrated on my sound and technique by using standard clarinet repertoire. To that end, I have played many ballets, including the Nutcracker with the Joffrey Ballet, over 100 musical theater productions on the bass clarinet, as well as many orchestral works, including Strauss, Ravel, Mahler, Gershwin, Tchaikovsky, Stravinsky, etc.”
- “There are other works for "Pierrot" ensemble - or that ensemble plus percussion - that require bass clarinet... several of which are quite good. The Stravinsky "Berceuses du Chat" and the Dallapiccola "Goether Lieder" are both very good; playing the Mozart Divertimenti (originally for 3 basset horns; arr. 2 clarinets and bass) would be valuable; also the Mozart Adagio (arr. clarinets and one bass); several clarinet quartets w/ Bass (the Waterson, the DesPortes , Uhl, etc. etc.)”

### Interviews

Although the questionnaires were emailed, a few of the participants requested phone interviews instead, and the same topics as the questionnaire were covered. For consistency and to match protocol with the questionnaire as closely as possible, the participants who were interviewed will remain anonymous.

### *Interview 1*

The first interviewed participant has a doubling background, is dedicated to music education, and “understands the physiology” behind creating a characteristic sound. “My experience teaching in public schools has shaped my approach to teaching clarinet and bass clarinet at the college level.” Often students in public school programs never have the opportunity to play an auxiliary instrument if they are a clarinetist, and the opposite is true for bass clarinetists who, inadvertently, never play soprano. This becomes a problem when students apply for university programs that only offer degrees in clarinet since bass clarinet students are typically not equipped to audition on clarinet. While this issue is not the focus of the dissertation, it is related, and bringing bass clarinetists into a clarinet focused program is also a model for programs incorporating bass clarinet.

Participant 1 explained the approach to teaching students who have only played bass clarinet, to transition to clarinet. “Bass clarinetists are accepted into the program, and expected to gradually transition over to soprano clarinet.” During their first year, they are introduced to the clarinet. However, “they primarily play, and give their first jury on bass clarinet.” Bass clarinet students are not tested on clarinet until their second year when they have had time to learn the instrument more proficiently. The first semester of study can be quite an adjustment for freshmen and introducing a new instrument is an added challenge.

Should students play both instruments? “Yes, starting in high school. Learning both instruments does not harm the embouchure of one or the other. In fact, students compete successfully on both instruments.”

What type of literature do you recommend? “I don’t use different studies or literature either...I use exactly the same studies that I do for clarinet. Albert, Langenus...Baermann.” To teach extended keys, “I simply extend the material down.” With regard to solo literature, there are many challenging works and “the bass clarinet is limited to appropriate teaching pieces. There are several clarinet pieces that also work well on bass clarinet,” for example “Igor Stravinsky’s *Three Pieces*, Wilson Osborne’s *Rhapsody* (originally for bassoon), and Carl Marie Von Weber’s *Concertino*.” Bassoon pieces that work well for bass clarinet... “Weber’s bassoon concerto, Weber’s *Hungarian Rondo* for bassoon and piano, Mozart’s bassoon concerto, C.P.E. Bach’s sonata for viola (later written for cello), and Hindemith’s bassoon sonata.”

Participant 1 also recommended, as another source for teaching pieces, transcriptions by Michael Davenport, who specializes in publishing transcriptions and new music for the bass clarinet from Alea Publishing found at [bassclarinet.org](http://bassclarinet.org).

Which orchestral excerpts do you recommend? “Use Shostakovich Violin Concerto,” and as introduction to bass clef use “the Bach cello suites, beginning with Davenport’s transcription in treble clef.” For first-year orchestral excerpts use “Tchaikovsky’s *Nutcracker Suite*, Liszt’s *Tasso, Lamento e Trionfo*, and Khatchaturian Piano Concerto.”

What instruments do you recommend? “I prefer the lyrical quality of Selmer bass clarinets to the Buffet, especially for notes over the break.” However, “Buffets are easier for clarinetists switching to bass clarinet.”

Additional commentary was with regard to sound and tone production. “There are generally two schools of thought: (1) creating a sound similar to the saxophone, and (2)

approaching the bass clarinet as a clarinet, but an octave lower.” Each approach depends on the goal and purpose of the bass clarinetist, as a soloist, orchestral player, or both.

Participant 1 approaches the bass clarinet as an extension of the clarinet.

### *Interview 2*

The second participant’s path to the bass clarinet is quite inspiring. Participant 2 learned bass clarinet the “old school” way, on the job, and now plays with one of the major orchestras in the United States. “I took time to become comfortable on the instrument and found equipment that works for me.” Equipment that will work best for each individual is very important. “For me the Buffet bass clarinets are best and Rico Grand Concert reeds, but finding the right mouthpiece made the most difference.” What do you recommend for mouthpieces? “The older Selmer mouthpieces,” they have a fuller sound. “Have them refaced [and] find a C\*, and if not, try the Grabner mouthpieces.”

Is bass clarinet important to a student’s career? Bass clarinet auditions require more than bass, also B-flat and E-flat. Today’s clarinetists must be very versatile, “it is not just about being a bass clarinetist...you have to be able to do everything, and everything well.” Start students in high school. Today’s equipment is much better and easier to play than in the past, and bass clarinet “opens a lot of doors for flexibility.” It is easier to transition from soprano to bass, rather than the other way. It’s difficult to win a principal job, so learning auxiliary instruments is very important.

### *Interview 3*

The third participant also has an orchestral background and plays with a major symphony in the United States. Is playing bass clarinet helpful for students' careers? "It's a smart thing to do, to play bass or E-flat." By playing both instruments, clarinetists have a better chance at a career. There aren't always openings for principal positions and it opens a lot of doors. "I highly recommend that students learn to play it well."

Should everyone learn to play bass clarinet? "I think it should be kind of an elective. I don't know if it should be required. I think it should be mostly for the people really interested in studying it. The instructor should emphasize the importance of the bass clarinet and recommend it to students, so that they want to study bass clarinet."

What inspired you to play the instrument? I had the chance to play a Buffet Prestige in college. "Sometimes they assign you to play bass clarinet." The instrument played so easily that I began to practice on my own.

When should a student begin playing bass clarinet? "They should wait until they are established on the clarinet. As long as the student understands the embouchure and articulation on the clarinet, then it is important to [start] bass clarinet. Age does not matter. I've had some high school [students] try bass, and some respond well and others do not respond well. Basically, I think that the most important thing is how to make a good embouchure and how to articulate, because that is exactly the same thing on the bass clarinet. Clarinet first. I also have some kids that only play bass clarinet. In some ways I see that as a bad thing. If they are aspiring to go to college and they have to play clarinet, they have no idea that they are supposed to play clarinet."

Are there any other suggestions you'd like to add about teaching bass clarinet? "I have most of my students play clarinet first. If everything is good on the clarinet, transitioning to bass will be fine. The only difference is that the embouchure is more relaxed, especially the bottom lip, so that the reed will vibrate more."

What instruments do you recommend? "Buffet is the best. For students... Buffet's newest model, which has improved with regard to key work. It costs much less and the mechanism is similar to the Prestige and it responds well." With regard to professional instruments, "some people prefer the Selmer, and that was the best instrument available before Buffet came out with the Prestige."

What mouthpieces do you recommend? "I play a Richard Hawkins. That works for me and I have been playing that for over 10 years now. I highly recommend it. Other mouthpiece makers such as Clark Fobes in San Francisco and Walter Grabner in Chicago are also good." Find a Selmer C\* and have it refaced, which is what many bass clarinetists are doing now. For students, Fobes, Grabner and Hawkins mouthpieces can be costly. A cheaper option is Vandoren, the B44, B40 and B50 are good options.

What methods and studies do you recommend? Methods and studies remain the same from clarinet to bass clarinet. "Rose, Klose, Jeanjean, Opperman *Velocity Studies*... I do it for fun, but it's a challenge because bass clarinet is bigger and the way you move your fingers on the bass clarinet is a little different. You articulate with your fingers... bigger movements."

Michael Drapkin's *Symphonic Repertoire for the Bass Clarinet* is good for orchestral excerpts. "The first book only, it has everything you need to know." Of course book one and two have things that were not previously available. "I really got serious

about bass clarinet excerpts.” One of the main differences between clarinet and bass clarinet are the altissimo fingerings. From thumb C and above “I almost never use the clarinet fingerings, [I use] almost all overblown fingerings.” “And if you do use longer fingerings, you have to use the tab.”<sup>207</sup>

What do you recommend for solo recital literature? As an orchestral bass clarinetist “I am focused on the orchestra. I don’t have time to organize many recitals. I like Daniel Dorff’s *In a Deep Funk* and recommend it. I play many transcriptions, also Schumann *Fantasy Pieces* on bass clarinet, or the *Romances*.” Participant 3 plays a great deal of chamber music and commissions pieces that include bass clarinet, and mentions John Adams’ *Chamber Symphony*. For chamber music you usually “have to play both B-flat and bass clarinet.”

Is there anything you would like to add about teaching bass clarinet? The most important thing about bass clarinet is that it is its own instrument, “it has its own voice. You have to find your own voice on the bass clarinet. Even though I approach it as if everything comes from clarinet. When I play the bass clarinet it is different. That is super important to know.”

## Conclusion

The bass clarinet has come into its own. I believe that all students should experience playing bass clarinet and gain an understanding of the repertoire available to the instrument before graduating with an undergraduate degree in clarinet performance. The results of the questionnaire and interviews show that there are several opinions about

---

<sup>207</sup> To play altissimo notes on clarinet we either lift our finger off of the first tone hole, or cover the hole half way. Since the bass clarinet has plateau keys, it is typically out of tune of the finger is just lifted. A smaller vent hole is in the middle of the first plateau key, and a metal extension or “tab” has been added to the bottom of the key so that the bass clarinet can slide his or her finger down to vent for altissimo notes.

teaching bass clarinet. All agree that learning bass clarinet is helpful to student careers and should be included in the curriculum, but whether or not all clarinetists should play bass clarinet remains questionable. Most agreed, but a few felt that it should only be for students interested in playing bass or for those who have already developed proficiency on soprano. While these reasons are valid, the music industry is changing, and with regard to bass clarinet, it is no longer just an auxiliary instrument. The repertoire has expanded, and the expectation for clarinetists to not only play bass clarinet, but to play it well, is becoming more common.

Not all students will be interested in playing bass clarinet as a solo instrument, but due to the expanding repertoire and the number of performance opportunities, I believe every student majoring in clarinet performance should play at least one piece for bass clarinet in a recital, and those focused on music education should spend at least a semester playing bass clarinet in the band and clarinet choir. Most likely, students going into performance will have to play bass clarinet at some point, and it is much easier to experience the challenges of the bass clarinet in the safety of a university ensemble and under the guidance of a teacher rather than in a professional setting.

Students focused on music education have it no easier. The role of the music educator is important and it is difficult to teach an instrument well that one has never played. While undergraduate students can practice the bass clarinet alone in a practice room, it is much more valuable for them to play in an ensemble where playing in time, in tune, and with good tone is a must. Undergraduates going into music education may not be interested in playing bass clarinet as a solo instrument, but in order to teach, they must understand what their pupils are going through, and they can only know by experiencing

it themselves. Music education students who play bass clarinet in the clarinet choir, or wind ensemble must overcome the challenges associated with it. In my experience, the process of overcoming obstacles has, as a result, enhanced my skills as a teacher, allowing me to help my students overcome the same difficulties. Therefore, requiring undergraduates who are completing degrees in music education to play bass clarinet in the university ensembles will only provide them with more skills to enhance their teaching.

One comment from the questionnaire suggested using the clarinet choir to expand performance opportunities on the bass clarinet, and it is a suggestion that I wholeheartedly agree with. Not only does the clarinet choir allow students to learn to play the bass clarinet properly with other musicians, but it also creates an opportunity for students to practice switching from one instrument to another. The repertoire for clarinet choir is expansive, and it is a valuable resource. Smaller universities may not have the instrumentation for many chamber works, so the clarinet choir (or smaller clarinet ensembles) provides another source for chamber music experience. Also, the clarinet choir is essentially the heart of the wind band. Matching intonation, timbre, and listening for balance are skills that carry over to the wind ensemble, benefiting the band program.

In orchestral, theater, and chamber ensembles it is imperative that bass clarinetists are also strong clarinetists, but there is a growing number of bass clarinet specialists. Should more schools offer specialization in bass clarinet? The majority of the participants from the questionnaire agreed, but not everyone. Specialized degrees in bass clarinet are already offered at several conservatories, and although the suggested curriculum in Chapter 4 is not designed for specialization in bass clarinet, it draws from curricula

established by these schools. Ultimately, whether a school should offer specialization in bass clarinet depends upon the goals of the students and teacher. I believe specialization in bass clarinet is more applicable to students at the graduate level. There is enough literature to support this; however if specialization were offered at the undergraduate level I would argue that students should also learn clarinet. Although it is possible to build a career playing bass clarinet, students still may be asked to play both instruments. Rather than offering an undergraduate degree with a specialization in bass clarinet, I believe it would be more beneficial to offer a degree that incorporates both instruments. After graduating, if students choose, they may continue their education to pursue specialty degrees. This philosophy supports the goal of the suggested curriculum, which is to help students become more versatile and able to create employment opportunities through performance of bass and soprano clarinet. Therefore, the curriculum assesses the performance level of methods and literature for the bass clarinet in correlation with clarinet literature of a similar level, promoting development of the two instruments simultaneously. It also aims to include all areas of bass clarinet performance (solo, orchestral, and chamber music) to establish a well-rounded approach.

If bass clarinet is incorporated into the curriculum, when should it be introduced? Responses to this question varied greatly. Some felt that students should begin in high school, others chose different years at the undergraduate level, and some felt that learning bass clarinet should begin in graduate school. From my experience, I began playing bass clarinet in graduate school, but I do not believe it is detrimental to begin in high school if possible. Ultimately, I believe the right time to start bass clarinet for students pursuing a performance degree is in the first semester of college and if possible, high school.

However, it is not yet common for students to double on bass clarinet in high school, so this curriculum introduces the bass clarinet beginning at the college freshmen level. I have kept in mind that every student enters the university at various levels of mastery and as a result, the curriculum is outlined Levels 1 through 5, so teachers can incorporate music appropriate for each individual's level of playing.

With regards to equipment, there are many options, and many reasons to choose one brand of bass clarinet or mouthpiece over another. The advice and comments from the questionnaire show the many factors one must consider when looking for equipment. Ultimately, budget, durability, availability, and consistency must be taken into account, and in the end it is a personal choice. The results of the survey and interviews have influenced my opinion about the importance of finding a mouthpiece that works for the individual. The mouthpiece is an important part of the clarinet, but it is even more critical for tone and projection on bass clarinet. Another factor to consider is how each mouthpiece pairs with different brands of bass clarinets. Mouthpieces that play well for Selmer bass clarinets do not always have the same results for Buffet, and vice versa. It is also apparent by the responses on the questionnaires that a low C instrument is necessary today, especially since much of the literature for bass clarinet requires the extended range. I agree with this, and recommend all universities and professional clarinetists have instruments with a low C extension.

The results for methods, excerpts, solo literature, and chamber music show the diversity of music being used to teach and play bass clarinet. Pieces most used have been incorporated into the suggested course of study, as well as works that were mentioned in the commentary. Also, several participants teach bass clarinet using clarinet literature.

This practice is prevalent enough to add a section to the curriculum that features pieces that can be played on both instruments.

My own experience with bass clarinet inspired me to start this project. When I played bass clarinet for the first time, I quickly learned that it is more than an auxiliary instrument. The role of the bass clarinet in orchestra, band, chamber music, and now as a solo instrument is becoming more prevalent, to the point that it should not be excluded from the curriculum. The questionnaires and interviews presented in this dissertation show the different approaches to teaching bass clarinet, which have helped form the basis of the suggested curriculum. My goal with this project is to create a guide for clarinet pedagogues who have never taught bass clarinet and are unfamiliar with the many resources available for teaching. This is also intended to help educators choose repertoire appropriate for students at various levels, and incorporate it with standard clarinet repertoire. Today's bass clarinet is more than an extension of the clarinet. It is its own instrument.

#### Suggested Course of Study for the Integration of the Bass Clarinet into the Clarinet Studio

The following curriculum is designed as a suggested guide for teachers who may want to start incorporating the bass clarinet into the clarinet studio. The pieces have been ranked according to the levels from Chapter 3. Feedback from the questionnaires and interviews has been taken into consideration when deciphering which works are most performed and taught. Therefore, this is not a complete listing of music for bass clarinet,

but rather a listing of standard works. Transcriptions are not included unless they are used significantly. Resources for additional bass clarinet repertoire are as follows:

1. Ebert, Brian. "Catalog of Chamber Music Requiring Soprano Clarinet and Bass Clarinet Doubling." paper, accessed March 29, 2015, [http://brianebert.com/brianebert.com/Doubling\\_List\\_files/EbertCatalog.pdf](http://brianebert.com/brianebert.com/Doubling_List_files/EbertCatalog.pdf) .
2. Hunt, Albert. "The Bass Clarinet Index: A Selectively Annotated Bibliography of Music Composed for the Bass Clarinet." DMA diss., The Julliard School, 1986.
3. International Bass Clarinet Research Center: <http://www.circb.info/>
4. Alea publishing: <http://www.bassclarinet.org/>

## Level 1

### Introduction to the Bass Clarinet: Reading and Videos

- Volta, *The Bass Clarinet* pp. 2-32
- Edward Palanker, "All You Wanted to Know About the Bass Clarinet and Have Been Afraid to Ask," *The Clarinet*, Vol. 2, Issue 4, pp. 12
- Edward Palanker, "The Highs and Lows of the Bass Clarinet," *The Clarinet* Vol. 27 Issue 2, pp. 60-61
- Edward Palanker, "Bass Clarinet 101, Bass Clarinet for Dummies," *The Clarinet* Vol 31, Issue 4, pp. 79-81
- Lawrie Bloom: Instructional videos, [www.woodwinds.daddario.com](http://www.woodwinds.daddario.com)

#### Clarinet

#### Bass Clarinet

#### Warm-ups

- |  |   |
|--|---|
| <ul style="list-style-type: none"> <li>• Long tone exercises</li> <li>• Register slurs (UNT handbook)</li> <li>• Burke, Kelly. Clarinet Warm-Ups Dorn</li> <li>• Schwartz, Richard The Tuning CD-CD &amp; Book <a href="http://thetuningcd.com">thetuningcd.com</a></li> </ul> | <ul style="list-style-type: none"> <li>• Long tone exercises for bass clarinet</li> <li>• <i>The Bass Clarinet</i> by Jean-Marc Volta</li> <li>• Long tones and Warm-ups pp. 20-25</li> <li>• Warm-up Exercises pp. 27-49 (Extends from low notes to clarion range.)</li> </ul> |
|--|---|

#### Scale Studies

- |   |   |
|---|---|
| <ul style="list-style-type: none"> <li>• All Major and Minor Scales memorized</li> <li>• Albert, J.B., <i>24 Varied Scales and</i></li> </ul> | <ul style="list-style-type: none"> <li>• All Major and Minor Scales memorized</li> <li>• Arnold, M. <i>The Bass Clarinet Scale</i></li> </ul> |
|---|---|

### *Excercises*

- Baermann, C., *Complete Method for Clarinet: Third Division, Op. 63*

### *Book*

- Rhoads, W. *Baermann for the Alto and Bass Clarinet*

### **Etudes**

- Hite, D. *Melodius and Progressive Studies, Books I & II*
- Kell, R. *17 Staccato Studies for Clarinet*
- Klosé, H. *Celebrated Method for the Clarinet*
- Lazarus, H. *Method for Clarinet Part II and III*
- Opperman, K. *Modern Daily Studies for the Clarinet, Books I & II*
- Rose, C., *32 Etudes*
- Thurston, F. *Passage Studies, Book I*
- Voxman, H. *Introducing the Alto or Bass Clarinet (1<sup>st</sup> semester only)*
- Rhoads, W. *Advanced Studies from the Works of Julius Weissenborn, Adapted for Alto and Bass Clarinet*
- Rhoads, W. *Etudes for Technical Facility for Alto and Bass Clarinet*
- Rhoads, W. *21 Foundation Studies for Alto and Bass Clarinet*
- Rhoads, W. *18 Selected Studies for Alto and Bass Clarinet*
- Gabriel, W. *Etudes for the Bass Clarinet*

### **Orchestral Excerpts**

- None – Fundamental stability and musicality should first be established
- None – Fundamental stability and musicality should first be established

### **Unaccompanied Solo**

- Debussy, C. arr. Galper. *Syrinx*
- Jacob, G. *Five Pieces for Solo Clarinet*
- Krenek, E. *Monologue*
- Okamura, K. *Two Pieces*
- Osborne, W. *Rhapsody*
- Dubois, P. *Sonata Breve*
- Hovhaness, A. *Lament, Op. 25*
- Tailleferre, G. *Sonata for clarinet solo*
- Arnold, M. *Fantasie, Op. 87*
- Auerbach, L. *Prayer for Bass Clarinet*
- Bach, J. S. *Allemande and Courante from Suite no. 1 for Cello*, trans. Glen A. Sargent.
- Cole, K. *Excursions, Variations on a theme of Paganini for Bass Clarinet*
- Schocker, G. *Weird Little Pieces*
- Vejslev, J. *Four Solos for Bass Clarinet Op. 97, 105, 106 & 107*

### **Concertos and Works with Accompaniment**

- Baermann, H. *Divertimento*
- Baermann, H. *Air Varie, No. 2*
- Berr, F. *Fantasia*
- Bennett, D. *Deepwood, for bass clarinet and piano*
- Bozza, E. *Ballade for bass clarinet*

- Debussy, C. *Petite Piece*
- Finzi, G. *Five Bagatelles*
- Hindemith, P. *Sonate*
- Kozeluh, J. *Concerto in E-flat Major*
- Krommer, F. *Concerto in E-flat Major, Op. 36*
- Lefevre, X. *Sonate No. 7*
- Marty, G. *Premiere Fantasy*
- Mendelssohn, F. *Sonata*
- Mozart, W.A. *Four Church Sonatas*
- Rossler, F.A. *Concerto in E-flat Major*
- Scarlatti, D. *Four Sonatas*
- Stamitz, C. *Concerto No. 3 in B-flat Major*
- Tartini, G. *Concertino*
- Telemann, G. P. *Sonata in C minor*
- Vaughan Williams, R. *Six Studies in English Folksong*
- Weber, C.M. von. *Concertino, Op. 26*
- Weber, C.M. von. *Concerto No. 1 in f minor*
- Brossé, D. *Elegy bass for clarinet and piano*
- Desportes, Y. *Andante and Allegro for bass clarinet and piano*
- Dieth, F. *Romanze for bass clarinet and piano*
- Eccles, H. *Sonata in G minor*
- Favoreel, J. *Zebus for bass clarinet and piano*
- Nedbal, M. *Sonatine for bass clarinet or clarinet and piano*
- Rarig, J. *Introduction & March bass clarinet and piano*
- Rasse, F. *Lied for bass clarinet and piano*
- Toda, A. *A Sketch for Bass Clarinet and Piano*

## Level 2

### Bass Clarinet Reading and Videos

- Edward Palanker, “Bass Clarinet Orchestra Auditions” *The Clarinet* Vol. 20, Issue 3 pp. 30
- Palanker, Edward, “Orchestra Audition Repertoire Master Class for Bass Clarinet,” *The Clarinet*, Vol. 20, Issue 4 pp. 34-35
- Micheal Lownstern: How not to Squeak on the Bass Clarinet  
<https://www.youtube.com/watch?v=1eQL-3demDA>

#### Clarinet

#### Warm-ups

- Register slurs (UNT Handbook)
- Long tone exercises
- Burke, K. *Clarinet Warm-Ups*

#### Bass Clarinet

- Bass long tone exercises
- Volta: Long tones pp. 24-49
- Warm-ups for interval and tonguing exercises, extreme low register and high notes pp. 54-73

## Scale Studies

- All Major and Minor Scales memorized
- Baermann, C. *Complete Method for Clarinet: Third Division, Op. 63*
- Klose, H. Major/Minor Scale Page
- All Major and Minor Scales memorized
- Rhoads, *Baermann for the Alto and Bass Clarinet*
- Arnold, *Bass Clarinet Scale Book*
- Major/Minor Chord Studies

## Etudes

- A. Carbonare, *Arte e Tecnica*
- Rose, C. *32 Etudes*
- Rose, C. *40 Studies*
- Kell, R. *17 Staccato Studies for the Clarinet*
- Opperman, K. *Velocity Studies for Clarinet*
- Opperman, K. *Intermediate Velocity Studies for Clarinet*
- Voxman, H. *Classical Studies*
- Bona, P. *Rhythmical Articulation*
- Gabriel, W. *Etudes for the Bass Clarinet*
- Rubio, P. *25 Progressive Studies for the Bass Clarinet*
- Sauro B. *Venti Studi for bass clarinet or basset horn*

## Orchestral Excerpts

Hadcock, Peter, *The Working Clarinetist*

- Beethoven, *Symphony No. 2*
- Beethoven, *Symphony No. 3*
- Beethoven, *Symphony No. 4*
- Brahms, *Symphony No. 1*
- Brahms, *Symphony No. 3*
- Mendelssohn, *Scherzo from Midsummer Night's Dream*
- Mendelssohn, *Symphony No. 4*
- Mozart, *Symphony No. 39*
- Mozart, *Symphony No. 40*
- Schubert, *Symphony in C Major*
- Schubert, *Unfinished Symphony*
- Tchaikovsky, *Symphony No. 5*
- Weber, *Der Freischutz Overture*
- Weber, *Oberon Overture*

Drapkin, Michael, *Symphonic Repertoire for the Bass Clarinet, Vol. 1, 2, and 3*

- Barber, S. *Overture to "The School for Scandal"*
- Berg, A. *Violinkonzert*
- Diamond, D. *Symphony No. 6*
- Gould, M. *Latin-American Symphonette*
- Grofe, *Grand Canyon Suite*
- Strauss, R. *Don Quixote*
- Liszt, F. *Tasso Lamento e Trionfo*
- Mahler, G. *Symphony No. 1*
- Mahler, G. *Symphony No. 2*
- Tchaikovsky, *Nutcracker Suite*

## Unaccompanied Solos

- Aitken, H. *Suite*
- Bennett, R. *Sonatina*
- Dorff, D. *In A Deep Funk: Dance Set*

- Cahuzac, L. *Arlequin*
- Stravinsky, *Three Pieces*
- Giron, A. *Three Bagatelles*
- Babin, V. *Divertissement Aspenois*
- Berio, L. *Lied*
- Bimstein, P. *Half Moon at Checkerboard Mesa*
- Caravan, R. *Excursions*
- Caravan, R. *Polychromatic Diversions*
- Giron, A. *Three Bagatelles*
- Harvey, P. *Three Studies on Themes of Gershwin*
- Piazzolla, A. *Tango Etudes*
- Saucier, G. *Three Pieces*
- Sutermeister, H. *Capriccio*
- Tomasi, H. *Sonatine Attique*
- von Koch, E. *Monolog nr. 3* (Soprano or Bass Clarinet)
- Erdman, D. *Monolog*
- Cole, K.R. *Excursions, Variations on a theme of Paganini*
- Opperman, K. *Un Seul*
- Peterson, G. *Homage to Donald Erb* for solo Bass Clarinet
- von Koch, E. *Monolog nr. 3* (Soprano or Bass Clarinet)

### Concerti and Works with Accompaniment

- Arnold, M. *Sonatina*
- Baermann, H. *Adagio*
- Bax, A. *Sonata*
- Busser, H. *Pastoral in F Major, Op. 46*
- Cahuzac, L. *Cantilene*
- Cavallini, E. *Adagio e Tarantella*
- Crusell, H. *Introduction, Theme and Variations on a Swedish Air for clarinet and orchestra, Op. 12*
- David, F. *Intro, Theme & Variations*
- Delmas, M. *Fantaisie Italienne*
- Donizetti, G. *Concertino in B-flat Major*
- Grovlez, G. *Lamento et Tarentelle*
- Honegger, A. *Sonatine*
- Hurlstone, W. *Four Characteristic Pieces*
- Jacob, G. *Mini Concerto*
- Jeanjean, P. *Carnaval of Venice*
- Jeanjean, P. *Aravesque*
- Proctor, S. *Lyrical Concerto for Bass Clarinet and Orchestra* (Piano Reduction)
- Erbse, H. *Vier Lyrische Stücke (Four Lyrical Pieces) Op. 35d* for Bass Clarinet (or Clarinet)
- Kibbe, M. *Night Music Op. 175* bass clarinet and piano
- Kibbe, M. *Sonata Op. 40* for bass clarinet (or bassoon) and piano
- Krol, B. *Fantasiestücke Op. 108* for bass clarinet or clarinet and piano
- Casas, B/ P., edited by Pedro Rubio, *Romanze* for bass clarinet and piano
- Schoek, O. *Sonate Op. 41* for Bass Clarinet and Piano
- Vejslev, J. *Duet for Bass Clarinet and Piano Op. 121*

- Lefevre, X. *Sonata in B-flat Op. 12 No. 1*
- Mathais, W. *Sonatina*
- Milhaud, D. *Sonatine*
- Milhaud, D. *Duo Concertante*
- Poser, H. *Sonate*
- Rabaud, H. *Solo de Concours*
- Reger, M. *Albumleaf and Tarantella*
- Saint-Saens, C. *Sonata*
- Schumann, R. *Three Duos*
- Stamitz, C. *Concerto in B-flat Major*
- Stanford, C. *Three Intermezzi, Op. 13*
- Starer, R. *Relationships*
- Tartini, G. *Concertino*
- Tuthill, B. *Fantasy Sonata, Op. 3*
- Wanhall, J. B. *Sonata in B-flat Major*
- Weber, C. M. von. *Introduction, Theme & Variations, Op. Posthumas*

### Level 3

#### Bass Clarinet Reading

- Volta, *The Bass Clarinet* p. 79 – 107
- Palanker, Edward. “Orchestral Audition Master Class for Bass Clarinet,” *The Clarinet*, Vol. 21 Issue 1 pp. 58-60 (November/December 1993)

#### Clarinet

#### Bass Clarinet

#### Warm-ups

- |  |  |
|--|--|
| <ul style="list-style-type: none"> <li>• Continue UNT register slurs</li> <li>• Long Tones</li> <li>• Incorporate Robert Springs Daily warm-ups</li> </ul> | <ul style="list-style-type: none"> <li>• Bass Clarinet Long Tones</li> <li>• Volta continued: Exercises through p. 82</li> </ul> |
|--|--|

#### Scale Studies

- |  |  |
|--|--|
| <ul style="list-style-type: none"> <li>• Diminished chords, whole tone scales, modes, major and minor thirds, fourths, fifths and sixths, diminished 7<sup>th</sup> chords.</li> </ul> | <ul style="list-style-type: none"> <li>• Martin Arnold, <i>Bass Clarinet Scale Book</i> – all scales in bass clef.</li> <li>• Major/Minor chord studies</li> </ul> |
|--|--|

## Etudes

- Jeanjean, *Vade Mecum*
- Bistch, M. *Douze Etudes de Rythme*
- Carbonare, A. *Arte e tecnica*
- Cavallini, E. *30 Caprices*
- Lang, R. *Short Cuts to Virtuoso Technique*
- Opperman, K. *Advanced Velocity Studies for Clarinet*
- Opperman, K. *Intermediate Velocity Studies for Clarinet*
- Polatschek, V. *Advanced Studies*
- Thurston, F. *Passage Studies*
- Berti, S. and Ludwig Milde, *Studi da Concerto op. 26: Versione per clarinetto basso*
- Berti, S. *Venti Studi (20 Studies) for bass clarinet or basset horn*
- Bona, P. *Rhythmical Articulation*
- Gabriel, W. *Etudes for the Bass Clarinet*
- Rubio, P. *25 Progressive Studies for the Bass Clarinet*
- Rubio, P. *30 Progressive Studies for the Bass Clarinet*

## Orchestral Excerpts

- Beethoven, L. *Symphony No. 6*
- Beethoven, L. *Symphony No. 8*
- Brahms, J. *Symphony No. 2*
- Brahms, J. *Symphony No. 4*
- Gershwin, G. *Rhapsody in Blue*
- Rachmaninoff, S. *Second Symphony*
- Rachmaninoff, S. *Second Piano Concerto*
- Rimsky-Korsakov, *Cappriccio Espanol*
- Rimsky-Korsakov, *Russian Easter Overture*
- Rossini, G. *Semiramide Overture*
- Mendelssohn, F. *Fingal's Cave Overture*
- Mendelssohn, F. *Symphony No. 3*
- Prokofiev, S. *Classical Symphony*
- Shostakovich, *Symphony No. 1*
- Sibelius, *Symphony No. 1*
- Smetana, *Bartered Bride Overture*
- Tchaikovsky, *Symphony No. 4*
- Bartok, B. *Violin Concerto No. 2*
- Dukas, P. *The Sorcerer's Apprentice*
- Dvořak, A. *Scherzo Capriccioso*
- Dvořak, A. *The Wild Dove*
- Franck, C. *Symphony in D Minor*
- Gershwin, G. *An American in Paris*
- Gershwin, G. *Concerto in F*
- Hindemith, P. *Symphonic Metamorphoses*
- Khachaturian, A. *Piano Concerto*
- Mahler, G. *Symphony No. 4*
- Mahler, G. *Symphony No. 8*
- Rachmaninoff, S. *Symphonic Dances*
- Shostakovich. *Violin Concerto*
- Verdi, G. "Duet Amneris e Radames," *Aida Act IV*
- Stravinsky, I. *Petroushka*

## Unaccompanied Solo Literature

- Arnold, M. *Fantasy for Clarinet, Op. 87*
- Busch, A. *Suite Op. 37a for bass clarinet or clarinet solo*
- Bach, J.S. *Suite for Cello solo, BWV 1007-1012 (bass clef version)*
- Becker, G. *Once upon a time*
- Busch, A. *Suite Op. 37a for bass*

- Caravan, R. *Polychromatic Diversions*
- Caravan, R. *Meditation and celebration*
- Kovacs, B. *Hommages*
- Larsen, L. *Dancing Solo*
- Penderecki, K. *Prelude*
- Persichetti, V. *Parable, Op. 126*
- Smith, W.O. *5 Pieces*
- Stravinsky, I. *Three Pieces*
- Sutermeister, H. *Capriccio*
- *clarinet or clarinet solo*
- Dubois, M. *Voltage Suite for solo bass clarinet*
- Genzmer, H. *Sonate for bass clarinet*
- Martin, T. *Grit'n Grind for solo bass clarinet*
- Montillo, J. *Introduction and Joropo*
- Patterson, G. *Hommage to Donald Erb*

### Concerti and Works with Accompaniment

- Baermann, H. *Concerto in E-flat*
- Bernstein, L. *Sonata*
- Bowen, Y. *Sonata*
- Bozza, E. *Fantasie Italienne*
- Brahms, J. *Sonatas No. 1 and No. 2*
- Burgmuller, N. *Duo in E-flat Major*
- Cooke, A. *Sonata in B-flat Major*
- Crussell, B. *Concerto in f minor, Op.1*
- Debussy, C. *Four Pieces*
- Devienne, F. *Deuxieme Sonata*
- Dunhill, T.F. *Phantasy Suite, Op. 91*
- Etlar, A. *Sonata No. 1*
- Finzi, G. *Concerto*
- Genzmer, H. *Sonate*
- Harvey, P. *Sonata*
- Hindemith, P. *Concerto*
- Jeanjean, P. *Scherzo*
- Lutoslawski, W. *Dance Preludes*
- Mercadante, S. *Concerto in B-flat Majore*
- Messenger, A. *Solo de Concours*
- Milhaud, D. *Duo Concertant*
- Mozart, W.A. *Concerto in A Major, K. 622*
- Penderecki, K. *Three Miniatures*
- Pleyel, I. *Concerto*
- Poot, M. *Sonatine*
- Poulenc, F. *Sonata*
- Callaway, A. *Concerto for Bass Clarinet and Chamber Orchestra*
- Erdmann, D. *Konzert für Bass-Klarinette und Orchester*
- Reiner, K. *Concerto for Bass Clarinet and Orchestra*
- Elton, O. *Sonata in Bb for Bass Clarinet and Piano*
- Heim, N. *Incantations of Mephistopheles Op. 39*
- Horst, E. *Bassclarpf für Bassklarinette und Klavier*
- Gabriel, W. *Ballade Op. 23 for Bass Clarinet (or Clarinet) and Piano*
- Gabriel, W. *Five Bagatelles for Bass Clarinet and Piano*
- Gabriel, W. *6 Elegies Op.82*
- Kibbe, M. *Fantasy Sonata Op. 208 Bass Clarinet and Piano*
- Petit, J. *Solipse I for Bass Clarinet and Piano*
- Pillin, B. *Scherzo Barbaro for Bass Clarinet and Piano*
- Prinz, A. *Nachtstück (Night Piece) for Bass Clarinet and Piano*
- Vejslev, J. *Four Solos for Bass Clarinet Op. 97, 105, 106, 107*

- Rossini, G. *Fantaisie*
- Rossini, G. *Variazioni*
- Schumann, R. *Fantasy Pieces*
- Sobeck, J. *Concert-Piece, Op. 10*
- Spohr, L. *Concerto No. 1*
- Spohr, L. *Potpourri, Op. 80*
- Spohr, L. *Theme & Variations*
- Stamitz, J. *Concerto in B-flat Major*
- Starer, R. *Dialogues*
- Weber, C.M. von. *Fantasia and Rondo*
- Weber, C.M. von. *Grand Duo Concertante, Op. 48*
- Wilder, A. *Sonata*

#### Level 4

#### Bass Clarinet Assigned Reading and Videos

- Volta, *The Bass Clarinet* pp. 108-117
- Harry Sparnaay, *The Bass Clarinet: A personal history* (CD included) pp. 11-59 – listening required
- Henri Bok, *Extended Techniques for Bass Clarinet* pp. 3-14
- Palanker, Edward. “Bass Clarinet Audition Repertoire Class No. 4,” *The Clarinet* Vol. 21, Issue 2 pp. 22-23
- Palanker, Edward. “Bass Clarinet Audition Repertoire Class No. 5” *The Clarinet* Vol. 21, Issue 3 pp. 34-35
- Palanker, Edward. “Gershwin’s Rhapsody in Blue for Bass Clarinet.” *The Clarinet* Vol. 23 Issue 2 pp. 20-21

#### Clarinet

#### Bass Clarinet

#### Warm-ups and Scale Studies

- |   |   |
|---|---|
| • whole tone scales, modes, major and minor thirds, sixths, octaves, chords | • whole tone scales, modes, major and minor thirds, sixths, octaves, chords |
| • broken & returning scales   | • broken & returning scales   |
| • Stark Arpeggio Studies for Clarinet, Op.39 (International)                | • Volta continued   |

#### Scale Studies

- |   |   |
|---|---|
| • Baermann, C. <i>Complete Method for</i> | • Martin A. <i>Bass Clarinet Scale Book</i> |
|---|---|

*Clarinet: Third Division Op. 63,*  
scales in 6ths, 4ths

- All Major/Minor Scales, Altissimo and low extended range from memory
- All Major/Minor Chords, memorized
- Diminished Chord Study
- Whole tone scale
- Scales in 3rds, 4ths, 5ths, 6ths, and Octaves

### Etudes

- Bistch, M. *Douze Etudes de Rythme*
- Uhl, A. *48 Studies*
- Bach, J.S. *Quinze Etudes*
- Baermann, H. *Parts 4 & 5 from the Complete Method*
- Jean-Jean, P. *18 Etudes*
- Jean-Jean, P. *16 Etudes*
- Jean-Jean, P. *Vade-Mecum*
- Jettel, R. *The Accomplished Clarinetist, Book I*
- Kovacs, B. *Hommages a'*
- Opperman, K. *Advanced Velocity Studies*
- Opperman, K. *Contemporary Sequences for Clarinet*
- Prinz, A. *24 Etudes*
- Wiedemann, L. *Thirty-Two Clarinet Studies*
- Uhl, A. *48 Studies*
- Berti, S. *Venti Studi*
- Bona, P. *Rhythmical Articulation*
- Gabriel, W. *Etudes for the Bass Clarinet*
- Rubio, P. *25 Progressive Studies for the Bass Clarinet*
- Rubio, P. *30 Progressive Studies for the Bass Clarinet*
- Volta, J. *The Bass Clarinet*
  - “Very Important: Dynamics” p. 84
  - Bach Study: open and normal fingerings p. 87

### Orchestral Excerpts

- Berlioz, H. *Symphony Fantastique*
- Copland, A. *El Salon Mexico*
- Debussy, C. *Afternoon of a Faun*
- Rimsky-Korsakov, N. *Sheherezade*
- Mendelssohn, F. *Symphony No. 4*
- Rachmaninov, S. *Symphony No. 2*
- Respighi, O. *Pines of Rome*
- Rimsky-Korsakov, N. *Coq d’Or*
- Rossini, G. *Figaro's Aria from "The Barber of Seville"*
- Mendelssohn, F. *Fingal's Cave*
- Bartók, B. *The Miraculous Mandarin*
- Gershwin, G. *Rhapsody in Blue*
- Mahler, G. *Symphony No. 6*
- Mahler, G. *Symphony No. 7*
- Mahler, G. *Symphony No. 9*
- Prokofiev, S. *Symphony No. 5*
- Rachmaninoff, S. *Symphony No. 2 in E Minor*
- Ravel, *Concerto for the Left Hand*
- Shostakovich, D. *Symphony No. 4*

- Overture*
- Prokofiev, S. *Peter and the Wolf*
  - Shostakovich, D. *Symphony No. 1*
  - Shostakovich, D. *Symphony No. 5*
  - Tchaikovsky, P. *Symphony No. 6*
  - Shostakovich, D. *Symphony No. 6*
  - Stravinsky, *Rite of Spring*
  - Wagner, *Götterdämmerung*

### Unaccompanied Solos

- Babin, V. *Divertissement Aspenois*
- Bach, J.S. (arr. Donatelli). *Toccatà & Fugue in D Minor*
- Bach, J. S. *Chromatic Fantasia*
- Berkeley, L. *Three Pieces*
- Childs, B. *Sonata*
- Caravan, R. *Polychromatic Diversions for Clarinet*
- Dubois, P. *Sonata Breve*
- Jacob, G. *Five Pieces for Clarinet*
- Krenek, E. *Monologue*
- Mandat, E. *Folk Songs*
- Mandat, E. *Etude for Barney*
- Mayar, J. *Raga Music for Solo Clarinet*
- Prinz, A. *Monolog*
- Stravinsky. *Three Pieces*
- Ambrosini, C. *Capriccio detto L'Ermafrodite*
- Babbitt, M. *My Ends are My Beginnings*
- Berio, L. *Sequenza IXc for bass clarinet solo*
- Carter, E. *Steep Steps*
- Dolphy, E. *God Bless the Child*
- Dorff, D. *Flowers of St. Francis (five scenes for solo bass clarinet)*
- Dorff, D. *In a Deep Funk, dance set for solo bass clarinet*
- Dubois, P. *Voltage, suite for solo bass clarinet*
- Gabriel, W. *Sonata Op. 72*
- Hyla, L. *Mythic Birds of Saugerties*
- Karlins, W. *Improvisation on 'Lines Where Beauty Lingers' for solo bass clarinet*
- Nyman, M. *Four Ostinatos for solo bass clarinet*
- Davidson, R. *Jump for solo bass clarinet*
- Sciortino, P. *Sillons*

### Concerti and Works with Accompaniment

- Armstrong, J. *Night Scenes*
- Babin, V. *Hillandale Waltzes*
- Bassi, L. *Concert Fantasia on Motives from 'Rigoletto'*
- Bax, A. *Sonata*
- Benjamin, A. *Le Tombeau de Ravel*
- Bozza, E. *Caprice-Improvisation*
- Busoni, F. *Concertino*
- Busoni, F. *Elegy*
- Cahuzac, L. *Variations on a Theme*
- Sciortino, P. *Calamus, Concerto for Bass Clarinet*
- Carter, E. *Concertino for bass clarinet and chamber orchestra*
- Reiner, K. *Concerto per clarinetto basso e orchestra: Tre Composizioni per Concerto*
- Gabriel, W. *Sonate für Bassklarinetten und Klavier, Op. 30*
- Gottschalk, L. *Sonata for bass*

- of a Valley*
- Copland, A. *Concerto*
  - Crusell, B. *Concerto No. 2*
  - Crusell, B. *Concerto No. 3*
  - Debussy, C. *Premiere Rhapsodie*
  - Devienne, F. *Premiere Sonata*
  - Françaix, J. *Concerto*
  - Françaix, J. *Tema con Variazioni*
  - Genzmer, H. *Sonatine*
  - Hetu, J. *Concerto*
  - Horovitz, J. *Sonatina*
  - Ireland, J. *Fantasy-Sonata*
  - Jeanjean, P. *Carnival of Venice*
  - Lazarus, H. *Fantasia On Airs from "IPuritani"*
  - Lovreglio, D. *Fantasy on Themes from Verdi's "La Traviata"*
  - Lutoslawski, *Dance Preludes*
  - Manevich, A. *Concerto*
  - Milhaud, D. *Scaramouche*
  - Muczynski, R. *Time Pieces*
  - Penderecki, *Three Miniatures*
  - Reinecke, C. *Introduction & Allegro Appassionata*
  - Reinecke, C. *Fantasy Pieces, Op. 22*
  - Reinecke, C. *Undine Sonata*
  - Rossini, *Introduction, Theme and Variations*
  - Scriabin, *7 Prelude for clarinet and piano*
  - Spohr, L. *Concerto No. 2*
  - Templeton, A. *Pocket Size Sonata and Pocket Size Sonata No. 2*
  - Weber, C.M. von, *Concerto No. 2 in E-flat clarinet and piano*
  - Heuk, S. *Sonate for Bass Clarinet (or Violoncello) and Piano Op. 23*
  - Horst, E. *Bassclarpf für Bassklarinette und Klavier*
  - Prinz, A. *Nachtstück (Night Piece) for Bass Clarinet and Piano*
  - Prinz, A. *Sonata for Bass Clarinet and Piano*
  - Sciortino, P. *Le Semainier for Bass Clarinet and Piano*
  - Semler-Collery, J. *Légende et Divertissement for Bass Clarinet and Piano*
  - Sluka, L. *D-S-C-H for bass clarinet and piano*
  - Sluka, L. *Sonáta pro fagot (nebo basklarinet) a klavír, rev. Josef Horák*
  - Termos, P. *Nieuw Werk for Bass Clarinet and Piano*
  - Zander, H. *Ballad for Bass Clarinet and Piano*

## Level 5

### Bass Clarinet Assigned Reading

#### Assigned Reading

- Harry Sparnaay, *The Bass Clarinet: A Personal History* pp. 59-165
- Henri Bok, *New Techniques for the Bass Clarinet* pp. 15-75
- Bourque, David. "The Bass Clarinetist's Workbook," *The Clarinet* Vol. 33

Issue 1 pp. 74-75

- Bourque, David. "A Practical Seminar in Four Parts, Part III: Clarinet and Bass Clarinet Transposition" *The Clarinet* Vol. 33 Issue 4 pp. 51
- Bourque, David. "The Bass Clarinetist's Workbook, Part II." *The Clarinet* Vol. 33 Issue 4 pp. 54-55
- Bourque, David. "The Bass Clarinetist's Workbook." *The Clarinet* Vol. 33 Issue 3 pp. 74-76
- Bourque, David. "The Bass Clarinetist's Workbook." *The Clarinet* Vol. 39 Issue 2

#### Additional Suggested Reading

- Bartolozzi, Bruno. *New Sounds for Woodwind*. Second edition. London: Oxford University Press, 1982.
- Rehfeldt, Richard. *New Directions for Clarinet*, revised edition. Los Angeles: University of California Press, 1994.
- Richards, Michael E. *The Bass Clarinet of the Twenty-First Century*. E & K Publishers, 1995.
- Sparnaay, Harry. *The Bass Clarinet: A Personal History*. Barcelona: Periferia Sheet Music, 2010.

### **Clarinet**

### **Bass Clarinet**

#### **Warm-ups**

- Warm-ups should cover the entire range of the instrument. At this stage, students should have developed a solid warm-up routine and rotate between the warm-ups assigned in previous levels.

#### **Scale Studies**

- Continue chord studies from previous guides. Maintain proficiency of scales. Major, minor, whole-tone, 3rds, 4ths, etc. Memorize diminished chords.

#### **Etudes and Studies**

- Incorporate previous methods as part of the daily warm-up routine. Clarinet etudes may also be incorporated, such as Uhl, *48 Studies for Clarinet* Vols. 1 and 2, Bitsch, *12 Rhythmic Studies for Clarinet*, Manevich, *10 Studies for Clarinet*.

#### **Orchestral Excerpts**

- |  |   |
|--|---|
| • Bartok, B. <i>Concerto for Orchestra</i>         | • Bloch, E. <i>Schelomo</i>                       |
| • Bartok, B. <i>The Miraculous Mandarin, Suite</i> | • Ravel, M. <i>Daphnis et Chloe First Series</i>  |
| • Bernstein, L. <i>On The Town</i>                 | • Ravel, M. <i>Daphnis et Chloe Second Series</i> |
| • Ginastera, A. <i>Variations</i>                  |   |

*Concertantes for Orchestra -  
clarinet variation*

- Kodaly, Z. *Dances of Galanta*
- Nielsen, C. *Symphony No. 5*
- Ravel, M. *Daphnis et Chloe*
- Shostakovich, D. *Symphony No. 9*
- Strauss, R. *Don Juan*
- Strauss, R. *Til Eulenspiegel*
- Stravinsky, I. *The Firebird*
- Stravinsky, I. *Petrushka*
- Stravinsky, I. *L' Histoire du Soldat*
- Tchaikovsky, P. *Francesca da Rimini*
- Borodin, B. *Polovtsian Dances*
- Schumann, W. *New England Triptych*
- Schumann, W. *Symphony No. 3*
- Schumann, W. *Symphony No. 7*
- Schoenberg, A. *Chamber Symphony No. 1*
- Strauss, R. *Til Eulenspiegel*
- Stravinsky, I. *The Firebird*

**Unaccompanied Solos**

- Bassett, L. *Soliloquies*
- Komives, J. *Flammes*
- Martino, D. *A Set for Clarinet*
- Mayar, J. *Raga Music*
- Messiaen, O. *Abyss of the Birds (from the Quartet for the End of Time)*
- Ran, S. *For an Actor: Monologue for Clarinet*
- Sierra, R. *Cinco Bocetos*
- Smith, William O. *Five Pieces*
- Tower, J. *Wings* (solo clarinet or bass clarinet)
- Zander, H. J. *Ballad for Bass Clarinet and Piano*
- Heucke, S. *Sonata for Bass Clarinet (or Violoncello) and Piano*
- Carter, E. *Steep Steps for solo bass clarinet*
- Hartzell, E. *Monologue 13: Configurations for Bass Clarinet*
- Kagel, M. *Schattenklänge, Three Pieces for Bass Clarinet*
- Ferneyhough, B. *Time and Motion Study I*
- Globokar, V. *Voix Instrumentalisée*
- Mandat, E. *Chips Off the Ol' Block*
- Martino, D. *Strata; Bass Clarinet Solo*
- Schaffer, B. *Monolog*
- Hartzell, Eugene, *Monologue 13, Configurations for Bass Clarinet*
- Singleton, A. *Argoru V/a for Bass Clarinet Solo*
- Tower, J. *Wings* (solo clarinet or bass clarinet)

**Concerti and Works with Accompaniment**

- Aho, K. *Concerto*
- Alwyn, W. *Sonata*
- Gabriel, W., *Sonata Op.30*
- Gabriel, W. *Sonatine Op. 36 for*

- Arnold, M. *Concerto No. 2* *bass clarinet and piano*
- Berg, A. *Vier Stucke, Op. 5* • Zander, H. *Ballad for Bass Clarinet and Piano*
- Bolcom, W. *Concerto* • Heucke, S. *Sonata for Bass Clarinet (or Violoncello) and Piano*
- Busoni, F. *Concertino* • Heuke, S. *Concerto for Bass Clarinet and Orchestra, piano reduction by Rainer Klaas*
- Carter, E. *Concerto* • Hyla, L. *Concerto for Bass Clarinet and Chamber Orchestra*
- Castelnuovo-Tedesco, M. *Sonata, Op. 128* • Lowenstern, M. *Spasm for bass clarinet and electronics*
- Corigliano, J. *Concerto* • Martino, D. *Triple Concerto for Clarinet, Bass Clarinet and Chamber Orchestra*
- Francaix, J. *Concerto* • Gabriel, W. *Sonatine Op. 36 for bass clarinet and piano*
- Denisov, E. *Sonate* • Sciortino, P. *As If for Bass Clarinet and Piano*
- Milhaud, D. *Concerto* • Termos, P. *Nieuw Werk for Bass Clarinet and Piano*
- Nielsen, C. *Concerto op. 57*
- Reger, M. *Sonata No. 1*
- Reger, M. *Sonata No. 2*
- Reger, M. *Sonata in B-flat Op. 107*
- Spohr, L. *Concerto No. 3*
- Spohr, L. *Concerto No. 4*
- Spohr, L. *Concerto No. 10*
- Tower, J. *Fantasy for clarinet and piano*
- Tower, J. *Concerto*
- Wallin, R. *Concerto*

### Chamber Music

- Albright, W. *Pit Band* (alto saxophone, bass clarinet, piano)
- Bodin, J. *6 Sonatas for Two Bass Clarinets* trans. Pedro Rubio. (bass clarinet duet)
- Bowen, Y. *Phantasy Quintet* (bass clarinet and string quartet)
- Festinger, R. *Tronometry* (flute, clarinet/bass clarinet, piano)
- Hindemith, P. *Septet for Winds* (Flute, Oboe, Clarinet in B-flat, Bass Clarinet, Bassoon, Horn, Trumpet)
- Janáček, L. *Mladi* (flute, oboe, clarinet, bass clarinet, bassoon, horn)
- Kibbe, M. *Pink Flamingos Tango* (clarinet and bass clarinet)
- Linke, N. *Prozession* (Bass Clarinet and Organ)
- Neukomm, S. “Make haste, O God” (mezzo-soprano, bass clarinet, piano) edited by Ph., Castejon. Köln: Castejon Music Editions, 2007.
- Nyman, M. *Manhatta for Soprano Voice and Bass Clarinet*
- Prinz, A. *Meeting* (clarinet and bass clarinet)
- Richardson, A. *Trio Sonata* (viola, bass clarinet, piano)
- Schuller, G. *Duo Sonata* (Clarinet and Bass Clarinet)
- Schoenberg, A. *Pierrot Lunaire* (flute dbl piccolo., clarinet dbl. bass clarinet, violin dbl. viola, cello, piano, voice)

- Sciortino, P. *As If for Bass Clarinet, Vibraphone and Marimba*
- Sciortino, P. *Sore* (clarinet and bass clarinet)
- Sierra, R. *Tres Pensamientos* (bass clarinet and percussion)
- Stewart, D. *Old Shoes Op. 54* (clarinet and bass clarinet)
- Thys, L. *A Gipsy for Ludo* (bass clarinet and accordion)

## BIBLIOGRAPHY

- Aber, Thomas Carr. "A History of the Bass Clarinet as an Orchestral and Solo Instrument in the Nineteenth and Early Twentieth Centuries and an Annotated, Chronological List of Solo Repertoire for the Bass Clarinet from Before 1945." D.M.A. Dissertation, University of Missouri-Kansas City, 1990.
- Aber, Thomas and Terje Lerstad. "Altissimo Register Fingering for the Bass Clarinet." *The Clarinet* 5, no. 2 (Summer 1982): 39.
- Alder, Jason. *Bass Clarinet Quarter-Tone Fingering Chart*. 2nd ed. Jason Alder, 2009-2013.
- Arnold, Martin. *Bass Clarinet Scale Book*. Toronto: Aztec Press, 2003.
- Bach, Johann Sebastian. *Suite for Cello Solo, BWV 1007-1012*. Edited by Hugo Becker. New York: C.F. Peters, 1946.
- Baines, Anthony. *Woodwind Instruments and Their History*. Rev. ed. New York: Dover Publications Inc., 1991.
- Bartolozzi, Bruno. *New Sounds for Woodwinds*. 2<sup>nd</sup> ed. London: Oxford University Press, 1982.
- Battisti, Frank L. *The Winds of Change*. Galesville: Meredith Music Publications, 2002.
- Becker, Günther. *Once upon a Time: für Bass-Klarinette in B*. Bad Schwalbach: Edition Gravis, 2001.
- Bennet, David. *Deepwood*. New York: Carl Fischer Inc., 1937.
- Berlioz, Hector. *Berlioz's Orchestration Treatise: A Translation and Commentary*. Translated by Hugh MacDonald. Cambridge: Cambridge University Press, 2002.
- Berlioz, Hector. *Treatise on Instrumentation*. Revised by Richard Strauss. Translated by Theodor Front. Melville: Belwin Mills, 1948.
- Berti, Sauro. *Ludwig Milde, Studi da Concerto op. 26: Versione per clarinetto basso*. Cesena: MusiGramma srl, 2011.
- Berio, Luciano. *Sequenza IXc for Bass Clarinet*. New York: Universal Edition, 1998.

- Bloom, Lawrie. "Developing Facility on the Bass Clarinet." *The Woodwind Player's Cookbook*. Gatesville: Hal Leonard, 2008: 12-14.
- . "Lawrie Bloom On How To Play Bass Clarinet Part 1." (YouTube video) posted February 11, 2009, accessed June 10, 2014, <https://www.youtube.com/watch?v=YdQKhEYPysY>.
- . "Lawrie Bloom On Bass Clarinet Reed Break In." (YouTube video) posted February 12, 2009, accessed June 10, 2014, <https://www.youtube.com/watch?v=TF3YZo99CAw>.
- . "Lawrie Bloom On How To Play Bass Clarinet Part 2." (YouTube video) posted February 11, 2009, accessed June 10, 2014, <https://www.youtube.com/watch?v=92OED-zbf5w>.
- Bok, Henri. *New Techniques for the Bass Clarinet* [1989]. Rotterdam: Henri Bok, 2005.
- Bona, Pasquale. *Rhythmical Articulation: Parts 2 and 3 from the Complete Method*. Trans. William D. Fitch. New York: Carl Fischer, 1969.
- Bozza, Eugene. *Ballade for Bass Clarinet and Piano*. San Antonio: Southern Music Company, 1958.
- Busch, Adolf. *Suite für Bassklarinette oder Klarinette solo*. Winterthur: Amadeus Verlag, 1980.
- Callaway, Ann. *Concerto for Bass Clarinet and Chamber Orchestra*. Ann Callaway Manuscript, 1987.
- Carter, Elliot. *Steep Steps for Solo Bass Clarinet*. Milwaukee: Boosey & Hawkes, 2001.
- Cruz, Cheyenne Bland, Kimberly Cole Luevano and Henri Bok. "A Pedagogical Guide to Playing Bass Clarinet in a Wind Ensemble," *The Clarinet* 41, no. 4 (September, 2014): 24-26.
- Desportes, Yvonne. *Andante & Allegro for B-flat Bass Clarinet and Piano*. San Antonio: Southern Music Company, 1969.
- Diethel, Friedrich. *Romanze for Bass Clarinet and Piano*. Ruisbroek: Metropolis Music Publishers, 1999.
- Dorff, Daniel. *In A Deep Funk: Dance Set for Solo Bass Clarinet*. King of Prussia: Theodore Presser Company, 2014.

- Drapkin, Michael. *Symphonic Repertoire for the Bass Clarinet*. 3 vols. Glenmore: Roncorp Publications, 1979-2004.
- Ebert, Brian. "Integrated Exercises for Clarinet and Bass Clarinet." DMA diss., University of Northern Colorado, 2012.
- Ebenhöh, Horst. *Bassclarpf für Bassklarinette und Klavier*. Vienna: Musikverlag Hehewarter, 2010.
- Eccles, Henry. *Sonata in G minor*. Transcribed by Norman A. Goldberg. New York: Belwin Inc., 1942.
- Elton, Owen. *Sonata in Bb for Bass Clarinet and Piano*. Owen Elton, 2010.
- Erdmann, Dietrich. *Konzert für Bass-Klarinette und Orchester*. Berlin: Ries & Erler, 1993.
- Ferneyhough, Brian. *Sonatina for 3 B-flat Clarinets and Bassoon (or Bass Clarinet)*. London: Hinrichsen Edition Ltd., 1966.
- Fobes, Clark. "Fine Tuning the Selmer Model 33 Bass Clarinet (Low C)." *The Clarinet* 14, no. 2 (Winter 1987): 20.
- Gabriel, Wolfgang. *Etudes for the Bass Clarinet: op. 85, Vol. 1 and 2*. Tacoma: Alea Publishing, 2004.
- . *Five Bagatelles for Bass Clarinet and Piano*. Tocomo: Alea Publishing, 2005.
- . *Sonate für Bassklarinette und Klavier, Op. 30, über Walisische Volkslieder*. Tocomo: Alea Publishing, 2002.
- . *Sonatine for Bass Clarinet and Piano, Op. 36*. Tocomo: Alea Publishing, 2003.
- . *Sonata, Op. 72*. Tacoma: Alea Publishing, 2003.
- Genzmer, Harold. *Sonate für Bassklarinette solo*. Leipzig: Henry Litoff's Verlag/C.F. Peters, 1984.
- Giampieri, Alamiro. *Passi Difficili e "A solo" per clarinetto e clarinetto basso*. 2 vols. Milan: G. Ricordi, 1936-41.
- Gingras, Michéle. *Clarinet Secrets: 52 Performance Strategies for the Advanced Clarinetist*. Lanham: The Scarecrow Press, Inc., 2004.

- . *More Clarinet Secrets: 100 Quick Tips for the Advanced Clarinetist*. Lanham: The Scarecrow Press, Inc., 2011.
- Goodman, Todd. *Concerto for Bass Clarinet and Orchestra*. Midland: Wrong Note Media Inc., 2008.
- Hadcock, Peter. *The Working Clarinetist: Master Classes with Peter Hadcock*. Glenmoore: Northeastern Music Publications, 1999 [2011].
- Hansen, Richard K. *The American Wind Band: A Cultural History*. Chicago: GIA Publications Inc., 2005.
- Hartzell, Eugene. *Monologue 13: Configurations for Bass Clarinet*. Vienna: Doblinger, 1983.
- Heaton, Rober. *The Versatile Clarinet*. New York: Routledge, 2006.
- Heim, Norman. *Incantations of Mephistopheles, Op. 39*. Medfield: Dorn Publications, 1990.
- . “Music for Bass Clarinet, Part I.” *The Clarinet* 6, no. 3 (Spring 1979): 18-21.
- . “Bass Clarinet Music, Part VII: Duos and Trios.” *The Clarinet* 9, no. 4 (Summer 1982): 36-38.
- . “Music for Bass Clarinet, Part VIII: Potpourri of Ensembles, Concertos, Etc.” *The Clarinet* 10, no. 4 (Summer 1983): 10-12.
- Heucke, Stefan. *Sonata for Bass Clarinet (or Violoncello) and Piano op. 23*. Mainz: Schott Musik International, 1999.
- Hoeprich, Eric. *The Clarinet*. New Haven: Yale University Press, 2008.
- Horst, Ebenhöh. *Bassclarpf für Bassklarinette und Klavier, Op. 109, 1b*. Wegscheid: Musikverlag Hehenwarter, 2010.
- Hunt, Albert. “The Bass Clarinet Index: A Selectively Annotated Bibliography of Music Composed for the Bass Clarinet.” DMA diss., The Julliard School, 1986.
- Hyla, Lee. *Concerto for Bass Clarinet and Chamber Orchestra*. New York: Pembroke Music Co., 1988.
- . *Mythic Birds of Saugerties for Solo Bass Clarinet in B flat*. New York: Carl Fischer, 2010.

- Jackson, Roland. *Performance Practice: A Dictionary-Guide for Musicians*. New York: Routledge, 2005.
- Jannotta, Roger. "God Bless the Child (An Analysis on an Unaccompanied Bass Clarinet Solo by Eric Dolphy)." *Jazzforschung/Jazz Research* 9: 37.
- Kalina, David Lewis. "The Structural Development of the Bass Clarinet." PhD diss., Columbia University, 1972.
- Karlins, William M. *Improvisations on "Lines Where Beauty Lingers" for Solo Bass Clarinet*, King of Prussia: Tritone Press, 2002.
- Kibbe, Michael. *Sonata, opus 40 for bass clarinet (or bassoon) and piano*. Rev. ed. Delaware Water Gap: Shawnee Press Inc., 2005.
- Klug, Howard. *The Clarinet Doctor*. Bloomington: Woodwindiana, 1997.
- Koons, Keith. "Bass Clarinet Teaching Survey Report." *The Clarinet* 18, no. 2 (February-March 1991): 38-39.
- Krebs, Jesse Daniel. "The Clarinetists of John Philip Sousa Band: 1892-1931." DMA Dissertation, Florida State University, 2006.
- Kroll, Oskar, and Diethard Riehm. *The Clarinet. Revised and with a Repertory*. New York: Taplinger Pub. Co., 1968.
- Lawson, Colin. *The Cambridge Companion to the Clarinet*. Cambridge: Cambridge University Press, 1995.
- Lockspeiser, Edward. "The Berlioz-Strauss Treatise on Instrumentation," *Music & Letters* 50, no. 1 (January 1969): 37-44.
- Mandat, Eric. *Chips Off the Ol' Block*. Cirrus Music, 1999.
- Manevich, Alexander. *Ten Studies for Clarinet*. Edited by Stanley Drucker. New York: International Music Company, 1967.
- Martin, Theresa. *Grit'n Grind*. Louisville: Potenza Music Publishing, 2013.
- Martino, Donald. *Strata; Bass Clarinet Solo*. Cincinnati: Apogee Press, 1967.
- . *Triple Concerto*. Newton: Dantalian, Inc., 1978.

- Millington, Barry. *Wagner*. New Jersey: Princeton University Press, 1984.
- Opperman, Kalmen. *Un Seul for Clarinet in B flat or Bass Clarinet in B flat*. New York: Carl Fischer, 2000.
- Owen, Elton. *Sonata in B-flat for bass clarinet and piano*. Copyright, Elton Owen, 2010.
- Palanker, Edward. "Bass Clarinet 101: Bass Clarinet for Dummies." *The Clarinet* 31, no. 4 (September, 2004): 79-81.
- Palanker, Edward. "The Five Bass Clarinet Suites of J.S. Bach." *The Clarinet* 25, no. 4 (Jul/Aug 1998): 42.
- Pellegrino, Michel. *Petit précis de clarinette basse*. Paris: Editions Henry Lemoine, 2009.
- Peterson, Geoffrey. *Homage to Donald Erb: for Solo Bass Clarinet*. King of Prussia: Tenuto Publications, 2002.
- Rarig, John. *Introduction & March for Bass Clarinet & Piano*. Los Angeles: Western International Music, Inc., 1968.
- Rehfeldt, Phillip. *New Directions for Clarinet. Rev. ed.* Berkley and Los Angeles: University of California Press, 1994.
- Reiner, Karel. *Concerto per clarinetto basso e orchestra: Tre Composizioni per Concerto*. Schott Music Panton, 1966.
- Rendall, F. Geoffrey. *The Clarinet*. New York: Philosophical Library Inc., 1954.
- Rhoads, William E. ed. *18 Selected Studies for Alto and Bass Clarinets*. San Antonio: Southern Music Company, 1963.
- . *21 Foundation Studies for Alto and Bass Clarinet*. San Antonio: Southern Music Company, 1965.
- . *Advanced Studies from the Works of Julius Weissenborn: Adapted for Alto and Bass Clarinets*. San Antonio: Southern Music Company, 1973.
- . *Baermann for the Alto and Bass Clarinet, from Division Three Celebrated Method for Clarinet by Carl Baermann, Op. 63*. San Antonio: Southern Music Company, 1963.

- . *Etudes for Technical Facility for Alto and Bass Clarinet*. San Antonio: Southern Music Company, 1965.
- Rimsky-Korsakov, Nikolai. *Principles of Orchestration*. Edited by Maximilian Steinberg. Translated by Edward Agate. New York: Dover, 1964.
- Rice, Albert R. *From the Clarinet d'Amour to the Contra Bass: A History of Large Size Clarinets, 1740-1860*. New York: Oxford University Press, 2009.
- Richards, Michael. *The Bass Clarinet of the Twenty-First Century*. E&K Publishers, 1995.
- . *The Clarinet of the Twenty-First Century*. E&K Publishers, 1992.
- Rickards, Guy. "Review Work: Lee Hyla: Bass Clarinet Concerto; Trans; Violin Concerto by Lee Hyla, Tim Smith, Laura Frautschi, Boston Modern Orchestra Project, Gil Rose." *Tempo* 58, no. 230 (Oct. 2004): 86-87, accessed January 9, 2015. <http://www.jstor.org/stable/3878756> .
- Roberts, Michael W. "Current pedagogical techniques of bass clarinet playing – a survey summary." *The Clarinet* 10, no. 3, (Spring, 1983): 24.
- Rubio, Pedro. *101 Studies for Bass Clarinet. 25 Progressive Studies, first register until low C*. Madrid: Música Didáctica S.L., 2004.
- . *101 Studies for Bass Clarinet. 30 Progressive Studies for German Notation System*. Madrid: Música Didáctica S.L., 2006.
- Ruggiero, Giuseppe. *Huit études atonales: pour clarinette*. Paris: A. Leduc, 1970.
- Russell, Jonathon. *Bass Clarinet Concerto*. Jonathon Russell Manuscript, 2014.
- Russell, Jonathon. *Bass Clarinet Double Concerto*. Louisville: Potenza Music Publishing, 2010.
- Schaffer, Boguslaw. *Monolog*. Vienna: Ariadne Verlag, 1980.
- Schoeck, Othmar. *Sonata, Op. 41 for bass clarinet and piano*. Wiesbaden: Breitkopf & Härtel, 1959.
- Schumann, Robert. *Fantasiestücke : für Klarinette*. Wiesbaden: Breitkopf & Härtel, 2006.

- Sciortino, Patrice. *Sillons: 3 Studies for Bass Clarinet Solo*. Paris: Gérard Billaudot Éditeur, 1991.
- Simmons, Melissa Sunshine. "The Bass Clarinet Recital: The Impact of Josef Horák on Recital Repertoire for Bass Clarinet and Piano and a List of Original Works for that Instrumentation," D.M.A. diss., Northwestern University, 2009.
- Sparnaay, Harry, Annelie de Man, and Paul Roe. *The Bass Clarinet: A Personal History*. Barcelona: Periferia Sheet Music, 2011.
- Sluka, Luboš. *D-S-C-H for Bass Clarinet and Piano*. Panton: Praha, 1997.
- Sluka, Luboš. *Sonata for Bass Clarinet and Piano*. Prague: Artia, 1972.
- Stravinsky, Igor. *Three Pieces for Clarinet Solo*. London: Chester Music, 1993.
- Toll, Rudolph. "Questions and Answers," *Jacob's Band Monthly* 4, no. 1 (October, 1919): 89-90.
- Tower, Joan. *Wings: for Solo B-flat Clarinet or Bass Clarinet*. New York: Associated Music Publishers, 1983.
- Van der Meer, John Henry. "The Typology and History of the Bass Clarinet." *Journal of the American Musical Instrument Society* 13, no. 1 (1987): 65-88.
- Volta, Jean-Marc. *The Bass Clarinet*. Paris: International Music Diffusion, 1996.
- Voxman, Himie. *Introducing the Alto or Bass Clarinet: A transfer method for intermediate instruction*. Chicago: Rubank, 1952.
- Wagner, Richard. *Orchestral Excerpts from Operas and Concert Works for Clarinet and Bass Clarinet*. Edited by Gudrun Hinze. New York: International Music Company, 1970.
- Wernick, Richard. *Telino's Acrobats for Unaccompanied Bass Clarinet*. King of Prussia: Theodore Presser Co., 2006.
- Young, P.T. *The Look of Music*. Seattle: University of Washington Press, 1980.
- Zander, Heinz Joachim. *Ballad for Bass Clarinet and Piano*. Hamburg: N. Simrock, 1993.

## VITA

Graduate College  
University of Nevada Las Vegas

Jennifer Iles

### Degrees:

Bachelor of Music, 2005  
McNeese State University

Master of Music, 2008  
University of North Texas

### Special Honors and Awards:

Phi Kappa Phi Honor Society  
Dean's List  
Graduate Honor Jury  
Euline & Horace Brock Merit Scholarship  
Patsy C. & Fred W. Patterson C. Scholarship  
Dean's Camerata Scholarship  
George Ruffin Marshall Scholarship  
Hardtner Performance Scholar

Dissertation Title: The Changing Role of the Bass Clarinet: Support for Its Integration into the Modern Clarinet Studio

### Dissertation Examination Committee:

Chairperson, Marina Sturm, D.M.A.  
Committee Member, Cheryl Taranto, Ph.D.  
Committee Member, Stephen Caplan, D.M.A.  
Committee Member, Kenneth Hanlon, D. M. A.  
Graduate Faculty Representative, Margot Mink Colbert, B. S.